

# 72" Type 2 Catch Basin w/ Knockouts

Meets or Exceeds WSDOT Standard Plan B-10.20-00  
 Catch Basins Constructed in Accordance with ASTM C-478  
 Rubber Gasket Conforms to ASTM C-443  
 Polypropylene MH Steps Conform to ASTM C-478

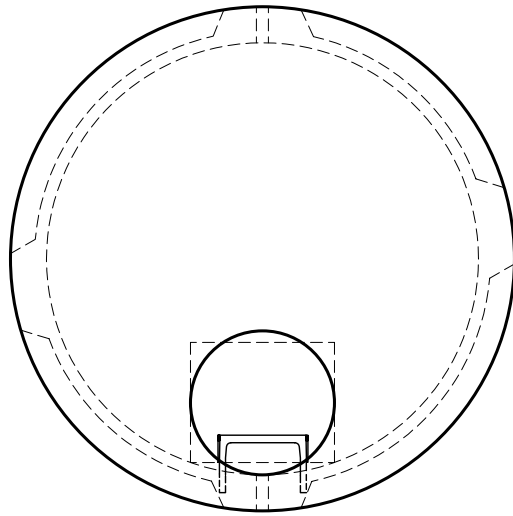

### TOP SLAB

24" Diameter Round or 20" x 24" Rectangular Hole

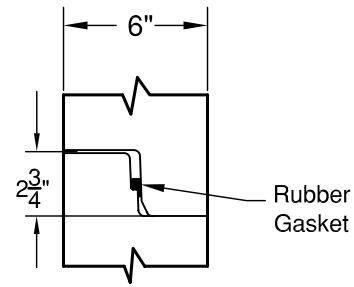

### JOINT DETAIL

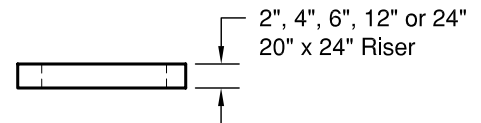
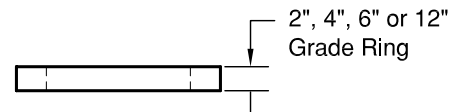

### WEIGHTS:

TOP SLAB:	8" - 3,620 lbs
RISER:	1' - 1,500 lbs
	2' - 3,000 lbs
	3' - 4,500 lbs
	4' - 5,740 lbs
	5' - 7,340 lbs
	6' - 8,560 lbs
	7' - 10,500 lbs
	8' - 11,900 lbs
HKO RISER:	5' - 5,340 lbs
	6' - 6,840 lbs
	7' - 8,340 lbs
	8' - 9,840 lbs
BASE SLAB:	12" - 5,300 lbs

### CONCRETE:

Fc= 4,000 psi @ 28 Days

### REINFORCING STEEL:

Welded Wire Fabric: ASTM A 497  
 Rebar: ASTM A615 Grade 60  
 Top Slab: 0.62 Sq in./ft e.w. min.  
 Riser: 0.18 Sq in./lin ft min.  
 Base Slab: 0.35 Sq in./lin ft min.

### PIPE PENETRATIONS:

Maximum Hole Size: 60"  
 Minimum Distance Hole to Hole: 12"  
 Holes Cored to Plan Specifications  
 Kor-N-Seal Connectors Available

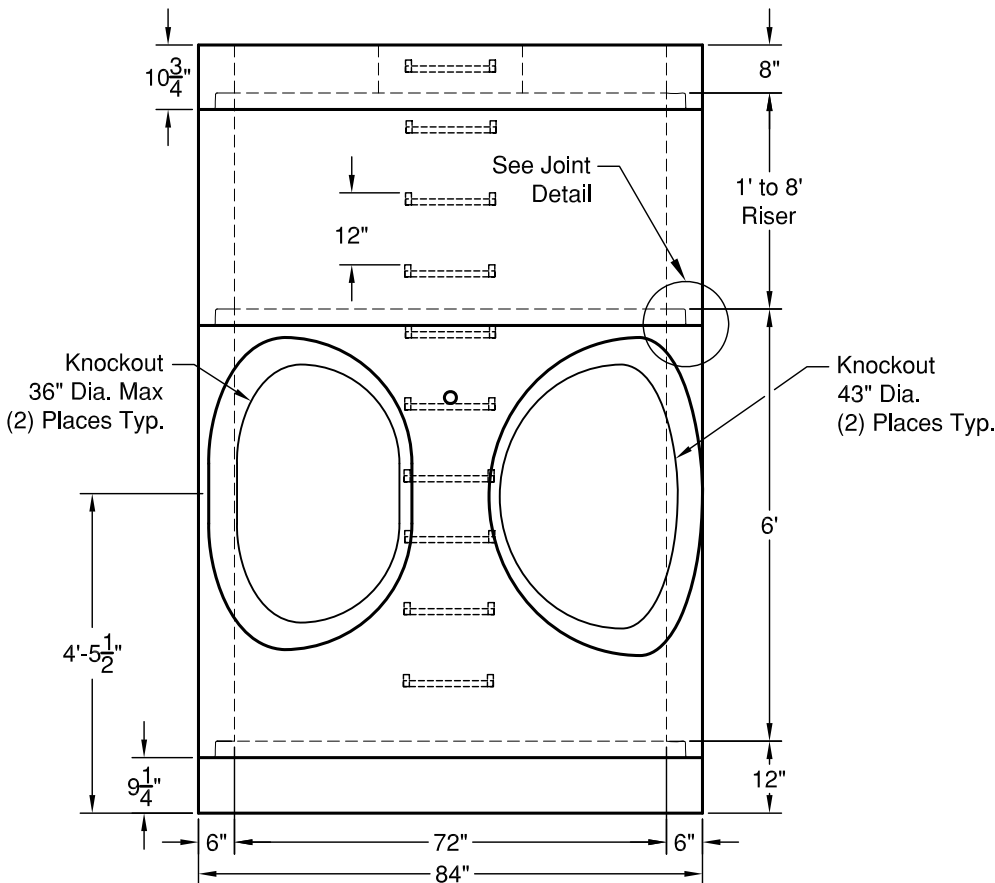

### ELEVATION AA

© 2011 Granite Precasting & Concrete, Inc.



# GRANITE™ PRECASTING & CONCRETE INC.

4116 BAKERVIEW SPUR • BELLINGHAM, WA 98226 • (360) 671-2251 • 1-800-808-2251 • FAX: (360) 671-0780