

Type 'X' With Drainage Slot

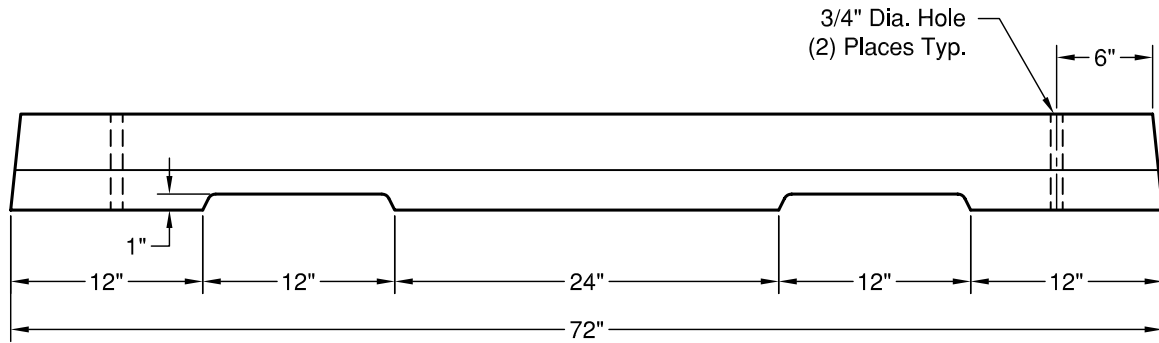

ELEVATION

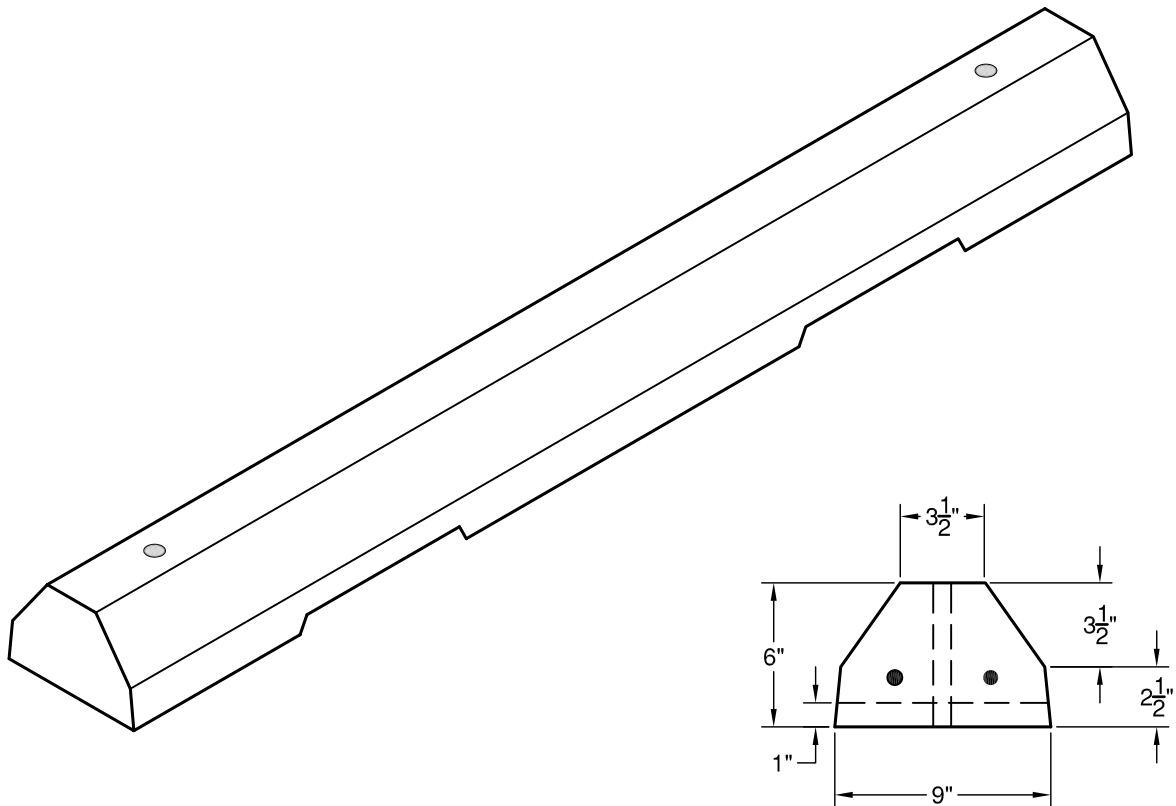

SECTION

Weight: 240 lbs
Concrete: Fc= 4,000 psi @ 28 Days
Reinforcement: (2) - #4 Rebar
ASTM A-615 Grade 60

326



GRANITE

**PRECASTING &
CONCRETE INC.**

4116 BAKERVIEW SPUR • BELLINGHAM, WA 98226 • (360) 671-2251 • 1-800-808-2251 • FAX: (360) 671-0780