

ELEVATION

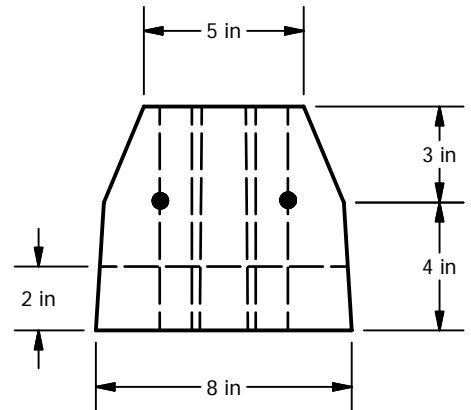
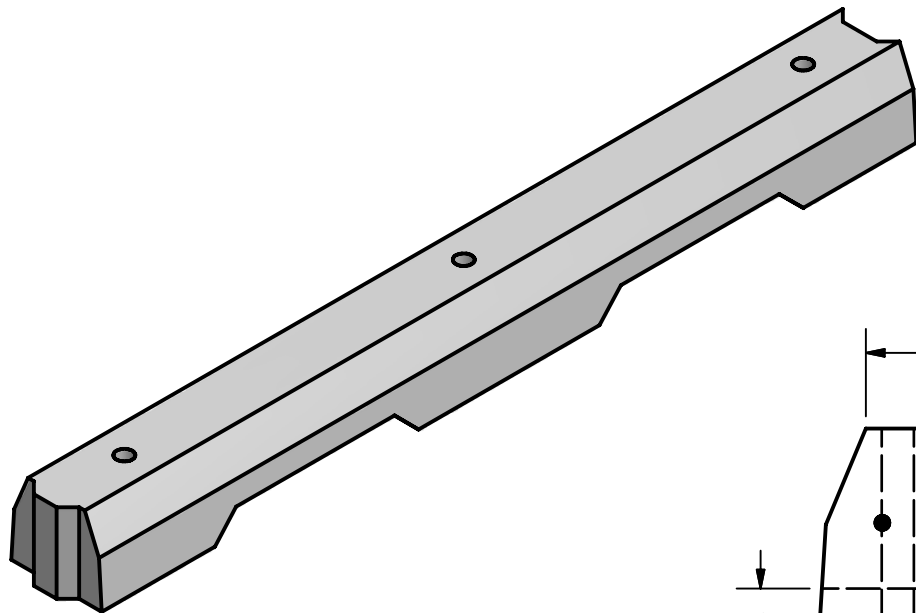

SECTION A-A
SCALE 1 / 6

Weight: 250 lbs
 Concrete: $f_c = 4,000$ psi @ 28 Days
 Reinforcement: (2) - #4 Rebar
 ASTM A-615 Grade 60

PROJECT:
WHEEL STOPS

STRUCTURE:
TYPE 'K' DRAINAGE SLOT

CUSTOMER:
GPC



GRANITE PRECASTING & CONCRETE INC.

4116 BAKERVIEW SPUR, BELLINGHAM, WA. 98226
 (360) 671-2251 1-800-808-2251 FAX: (360) 671-0780

DRAWN:	CHA	DATE:	3/27/06	SHEET:	1
CHECKED:	CHA	DATE:	3/27/06	SCALE:	1"=1'-0"
0	3/27/06	CHA	ISSUE FOR APPROVAL		
THIS DOCUMENT CONTAINS PROPRIETARY INFORMATION THAT SHALL NOT BE COPIED OR DISCLOSED TO OTHERS WITHOUT THE EXPRESS WRITTEN PERMISSION OF GRANITE PRECASTING AND CONCRETE.					