

Truck Wheel Stop

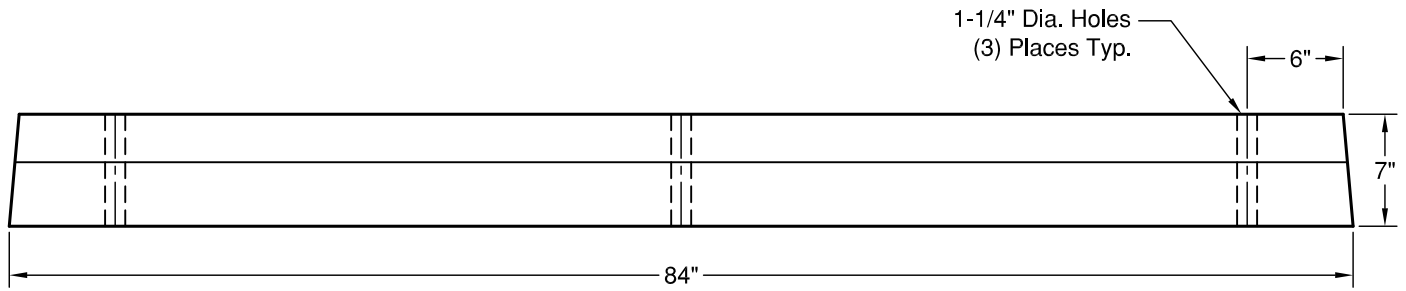

ELEVATION

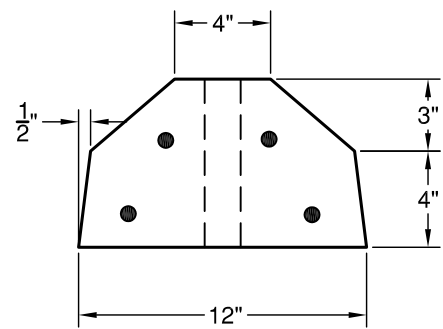
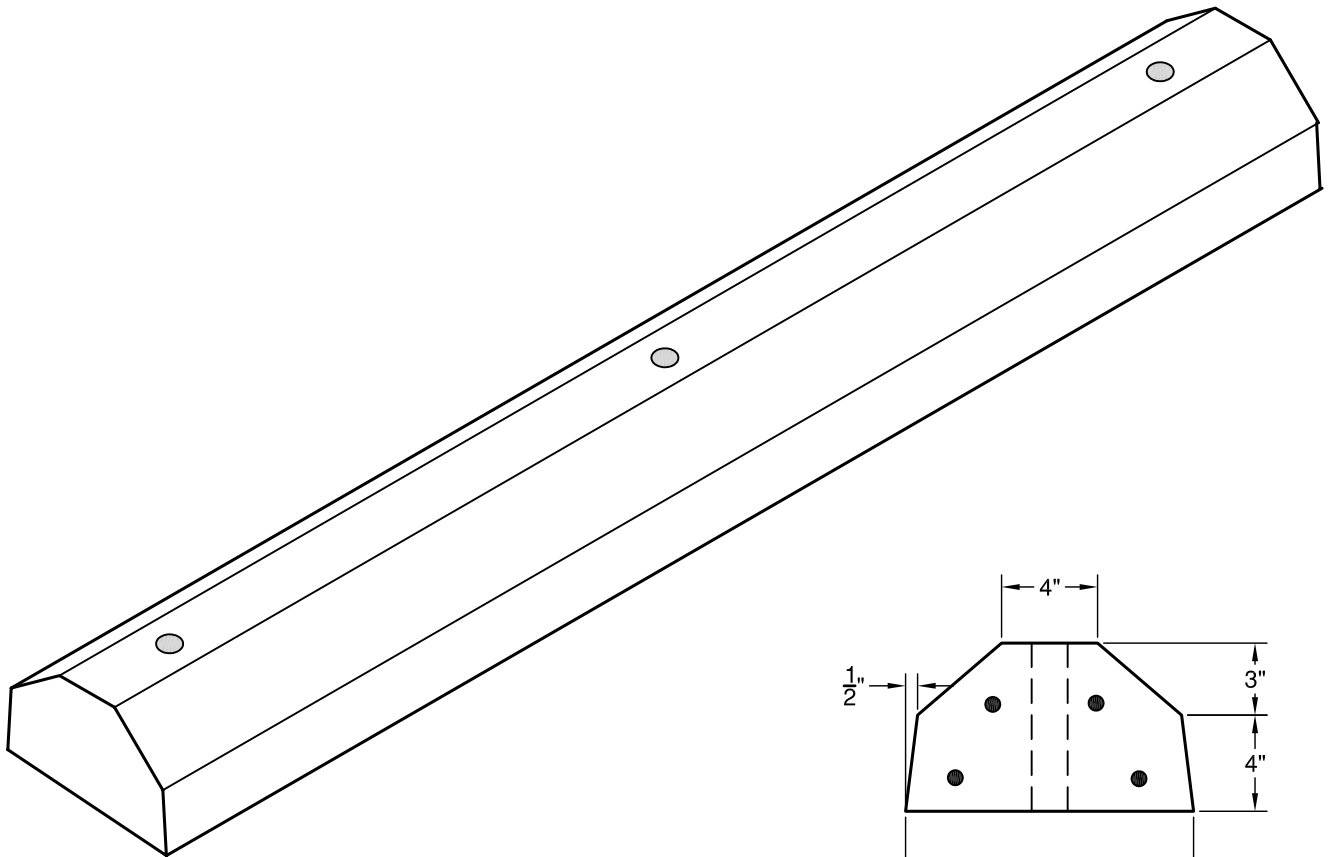

SECTION

Weight: 460 lbs
Concrete: $F_c = 4,000$ psi @ 28 Days
Reinforcement: (4) - #5 Rebar
ASTM A-615 Grade 60

337



GRANITE

**PRECASTING &
CONCRETE INC.**

4116 BAKERVIEW SPUR • BELLINGHAM, WA 98226 • (360) 671-2251 • 1-800-808-2251 • FAX: (360) 671-0780