

# 5 x 7.5 Oil Water Separator

500 Gallon  
Capacity

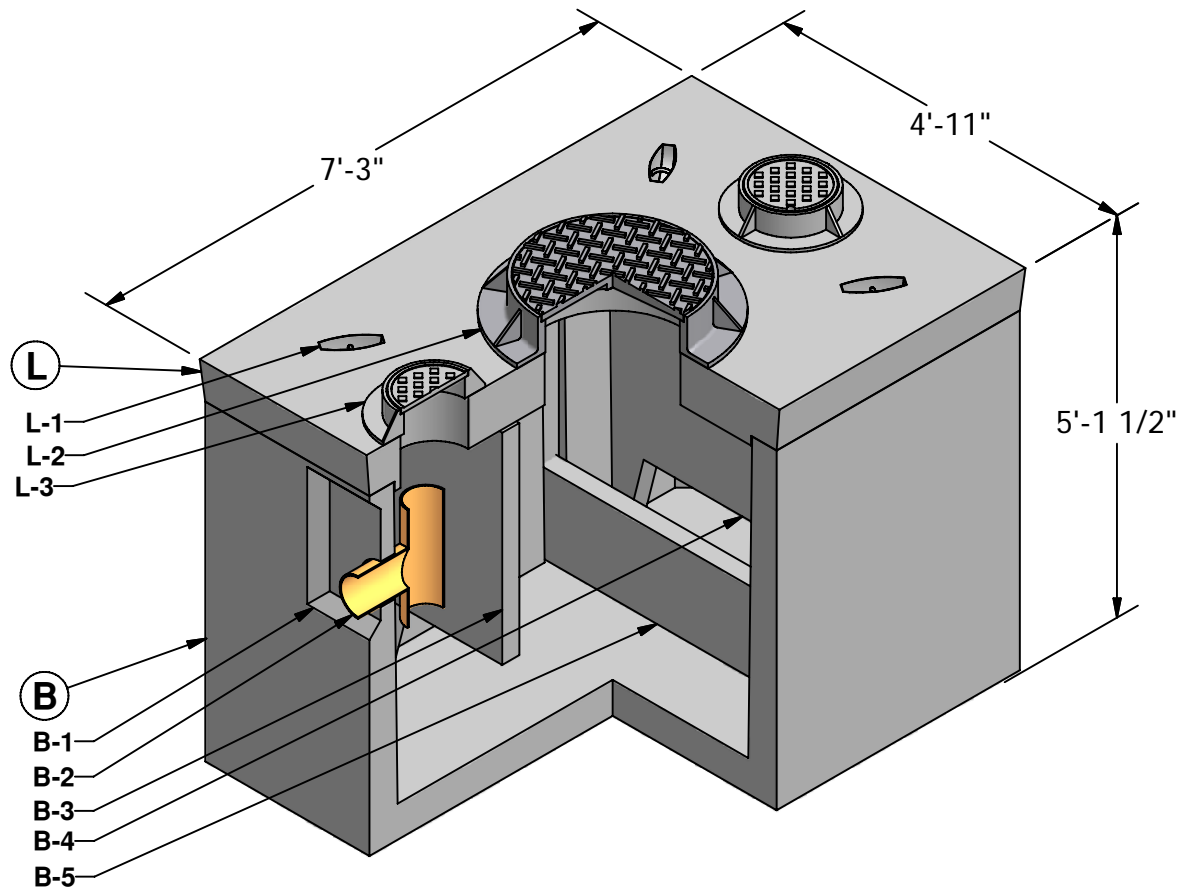

(L) LID (2,750 lbs)

- L-1. UTILITY ANCHOR
- L-2. 24" DIA. RING & COVER (OPTIONAL)
- L-3. INSPECTION COVER (OPTIONAL)

(B) BASE (8,460 lbs)

- B-1. 1'-6" x 1'-5" KNOCKOUT
- B-2. OUTLET PIPE AND TEE (BY OTHERS)
- B-3. OIL RETAINING BAFFLE
- B-4. FLOW DIFFUSER BAFFLE
- B-5. SLUDGE WEIR



**GRANITE**<sup>TM</sup>

**PRECASTING &  
CONCRETE INC.**

4116 BAKERVIEW SPUR • BELLINGHAM, WA. 98226 • (360) 671-2251 • 1-800-808-2251 • FAX: (360) 671-0780

# 5 x 7.5 Oil Water Separator

500 Gallon Capacity

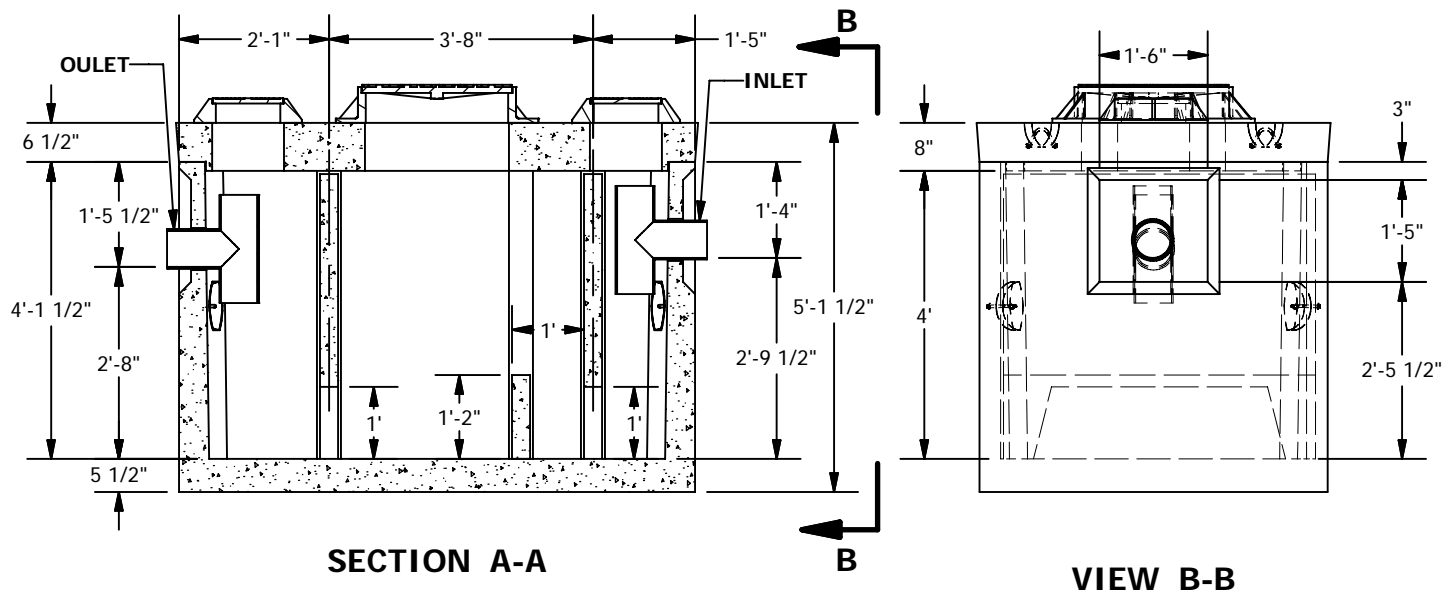
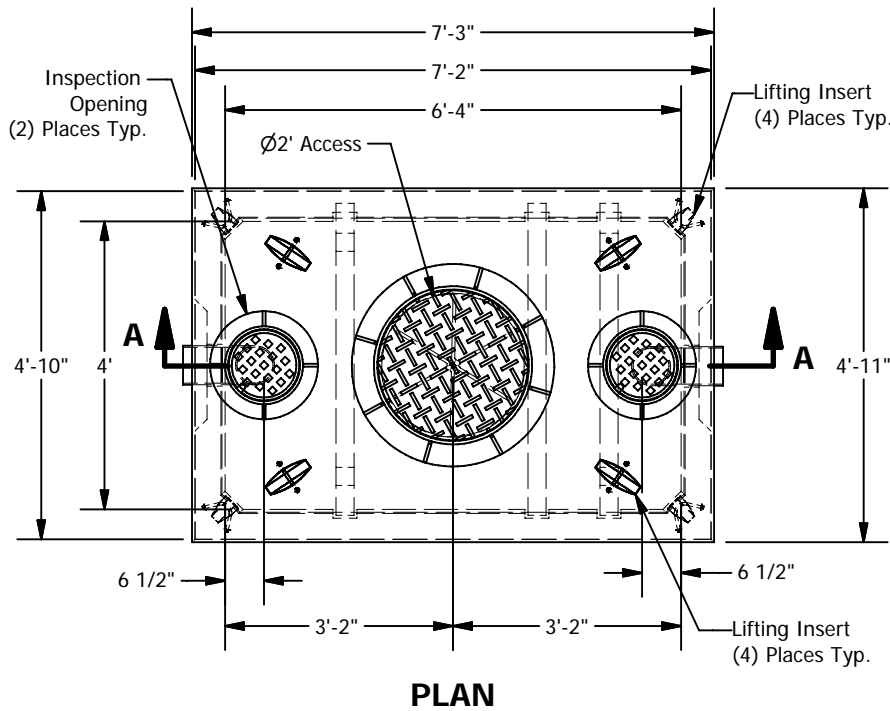

## SPECIFICATIONS

1. Concrete: Fc=5,000 psi @ 28 days
2. Rebar: ASTM A-615 Grade 60
3. Design: ASTM C-857 "Minimum Structural Design Loading for Underground Precast Concrete Utility Structures"
4. Loads: AASHTO HS-20
5. Backfill with granular free draining material (sand or pea gravel) free of stones or cobbles greater than 4" dia.
6. All pipe to be supplied and installed by contractor.
7. Contractor to field install baffle.
8. Fill with clean water prior to start up.
9. Items shown are subject to change without notice.