

5 x 7.7 Oil Water Separator

950 Gallon
Capacity

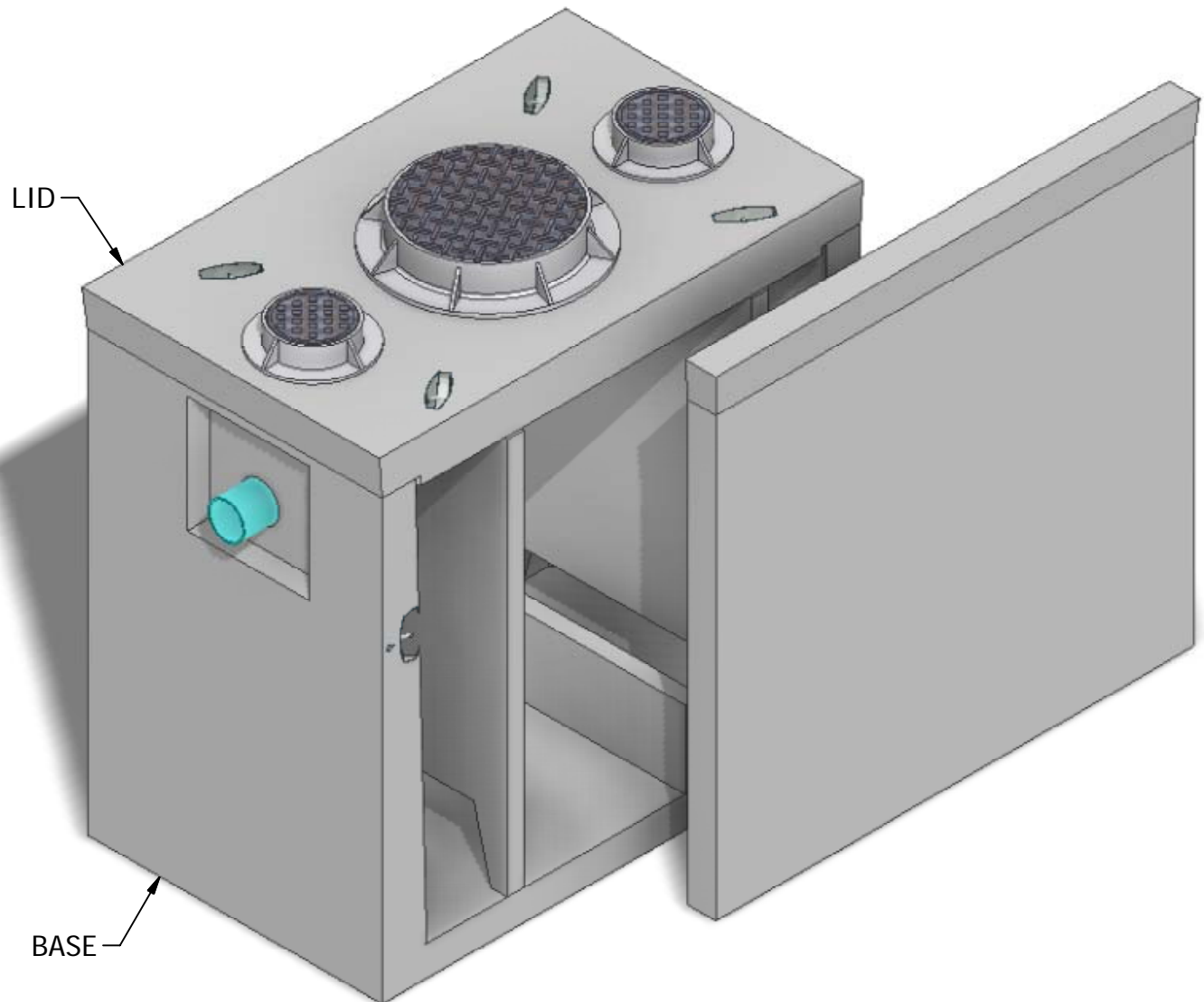

INTERIOR DIMENSIONS:
4'W x 6'-4"L x 6'H

WEIGHTS:
LID (2,750 lbs)
BASE (11,600 lbs)

NOTE: Side panel has been shifted to show internal view and is not removable.

© 2011 Granite Precasting & Concrete, Inc.



GRANITETM

**PRECASTING &
CONCRETE INC.**

4116 BAKERVIEW SPUR • BELLINGHAM, WA. 98226 • (360) 671-2251 • 1-800-808-2251 • FAX: (360) 671-0780

5 x 7.7 Oil Water Separator

950 Gallon Capacity

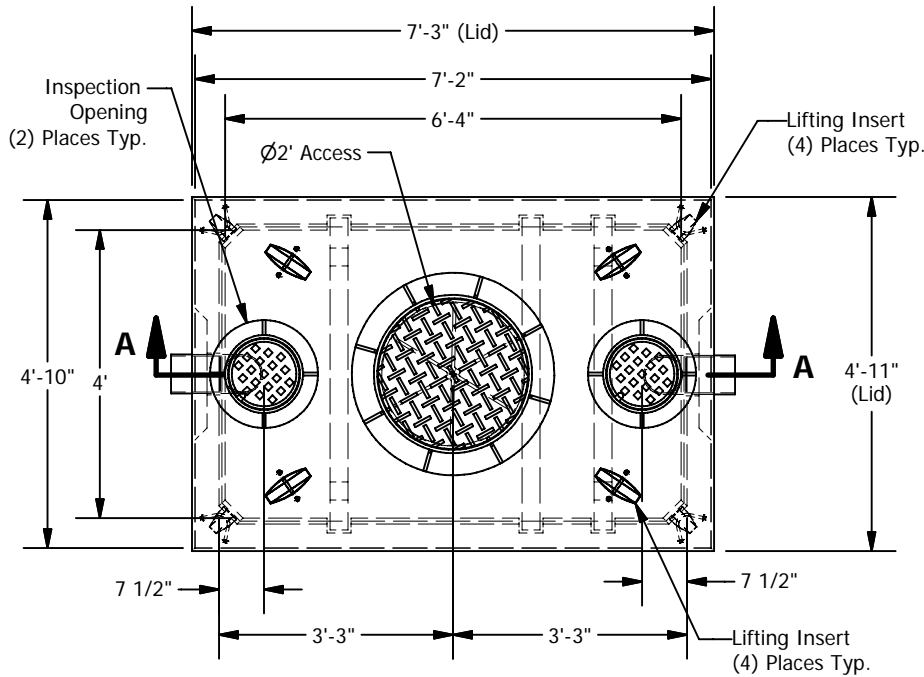

PLAN

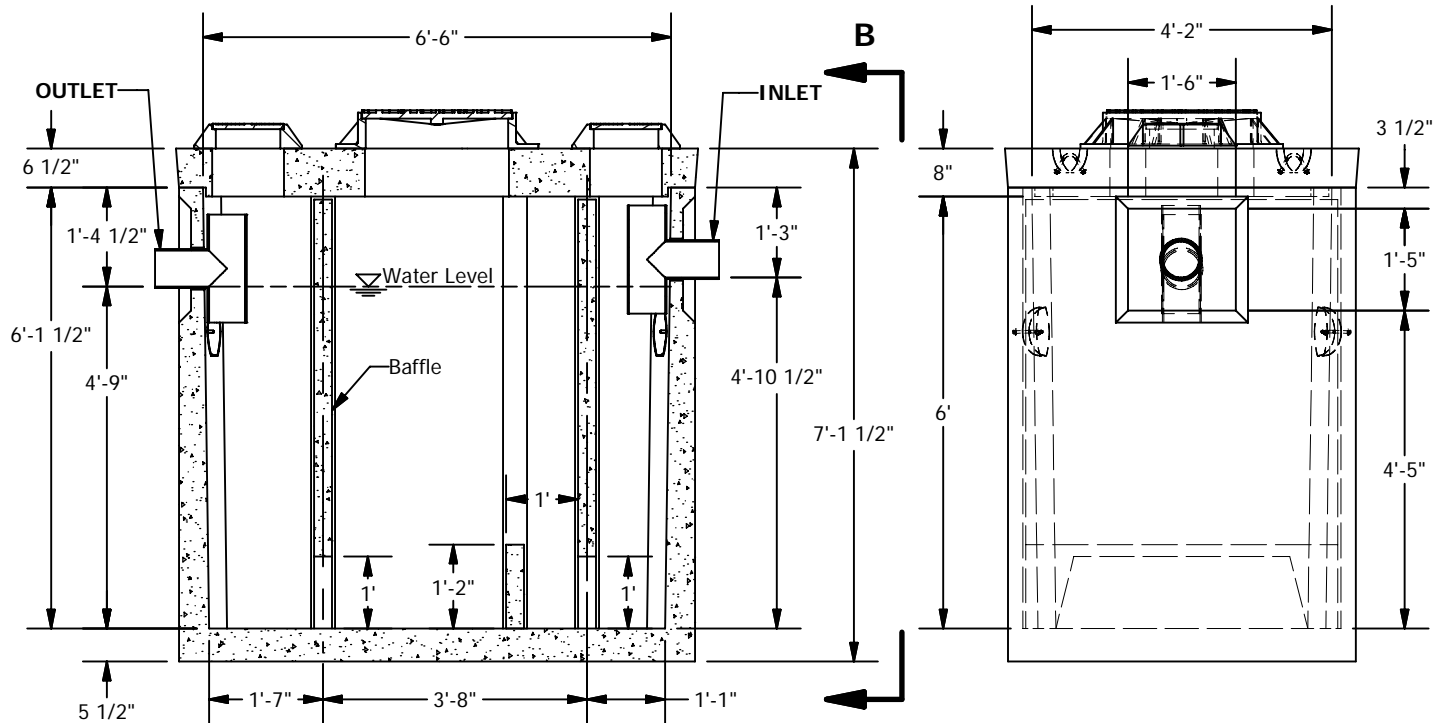

SECTION A-A

VIEW B-B

© 2011 Granite Precasting & Concrete, Inc.

SPECIFICATIONS

- Concrete: Fc=5,000 psi @ 28 days
- Rebar: ASTM A-615 Grade 60
- Design: ASTM C-857 "Minimum Structural Design Loading for Underground Precast Concrete Utility Structures"
- Loads: AASHTO HS-20
- Backfill with granular free draining material (sand or pea gravel) free of stones or cobbles greater than 4" dia.
- All pipe to be supplied and installed by contractor.
- Contractor to field install baffle.
- Fill with clean water prior to start up.
- Items shown are subject to change without notice.