

6 x 12 Grease Interceptor

2,000 Gallon
Capacity

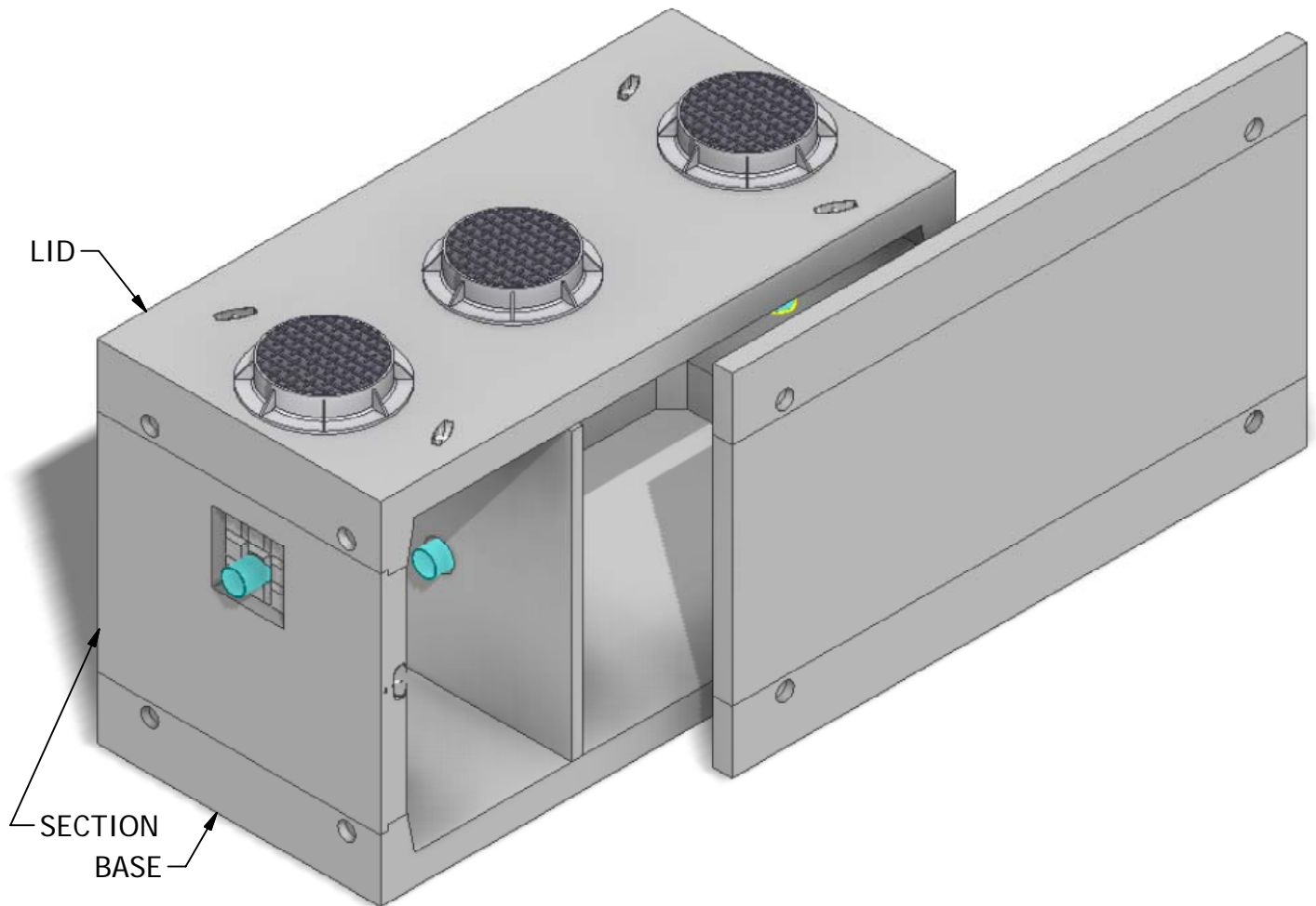

INTERIOR DIMENSIONS:
6'W x 12'L x 6'-5"H

WEIGHTS:
LID (8,740 lbs)
SECTION (11,100 lbs)
BASE (9,680 lbs)

NOTE: Side panel has been shifted to show internal view and is not removable.

© 2011 Granite Precasting & Concrete, Inc.



GRANITETM

**PRECASTING &
CONCRETE INC.**

4116 BAKERVIEW SPUR • BELLINGHAM, WA. 98226 • (360) 671-2251 • 1-800-808-2251 • FAX: (360) 671-0780

