

7 x 7.7 Meter Vault

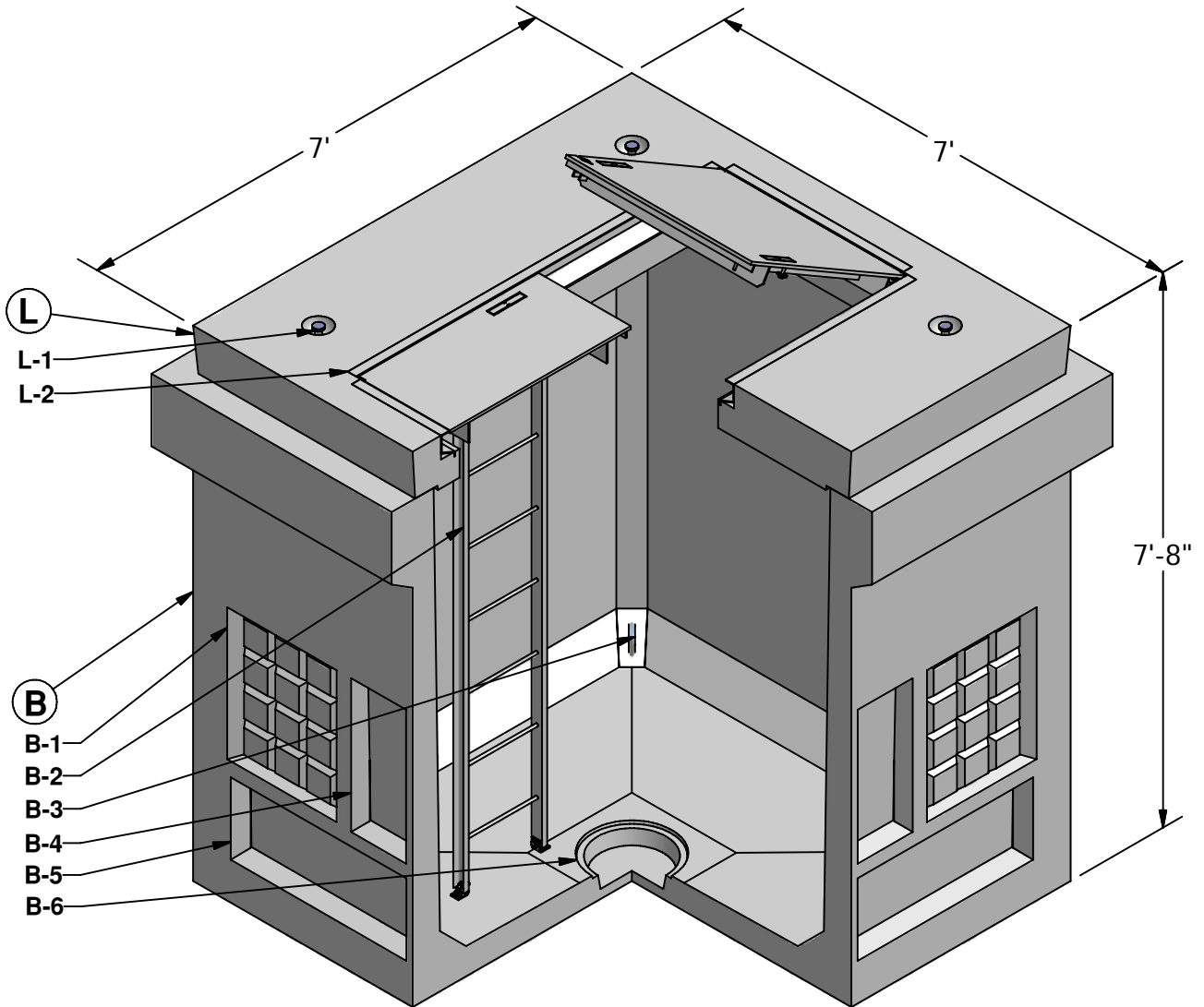

Ⓛ LID (5,462 lbs)

- L-1. LIFTING INSERT
- L-2. 3' X 6' GALV. DBL. DOOR HATCH

Ⓑ BASE (15,907 lbs)

- B-1. 1'-6" X 2'-0" KNOCKOUT
- B-2. GALV. LADDER (OPTIONAL)
- B-3. GALV. PULLING IRON
- B-4. 9" X 2'-0" KNOCKOUT
- B-5. 2'-8" X 1'-0" KNOCKOUT
- B-6. 12" DIA. SUMP

D-25



GRANITETM **PRECASTING & CONCRETE INC.**

4116 BAKERVIEW SPUR • BELLINGHAM, WA. 98226 • (360) 671-2251 • 1-800-808-2251 • FAX: (360) 671-0780

7 x 7.7 Meter Vault

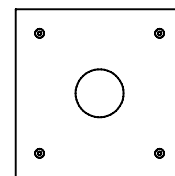
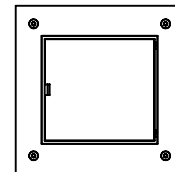
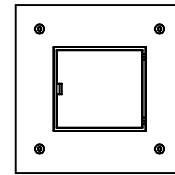
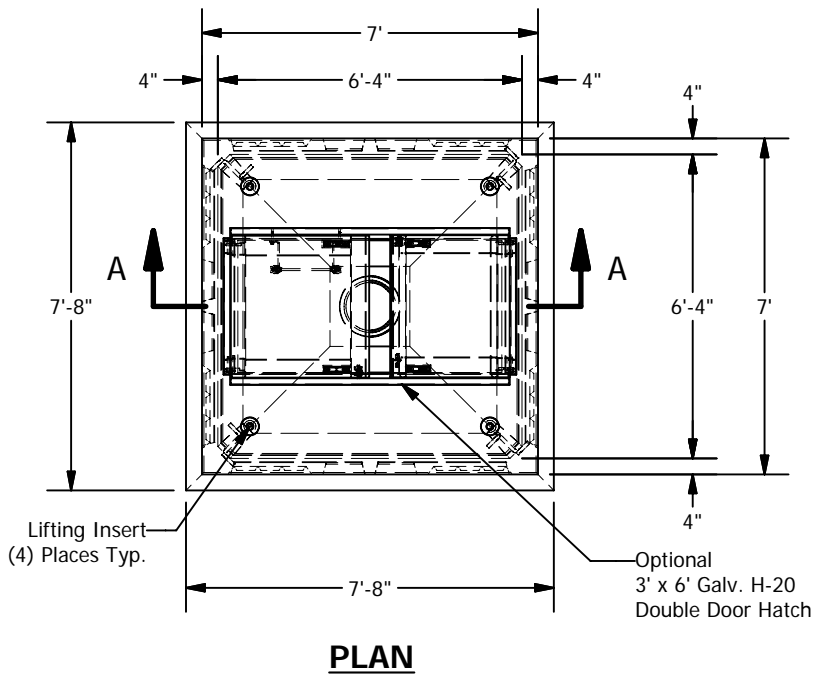

LID OPTIONS

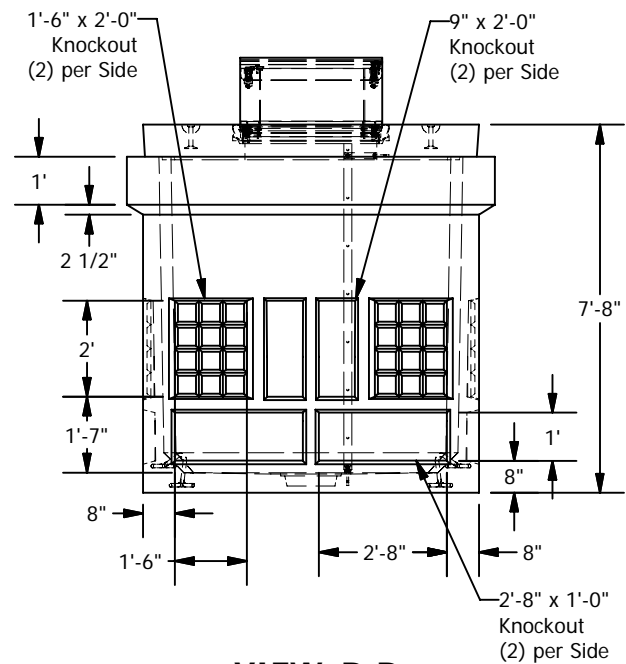
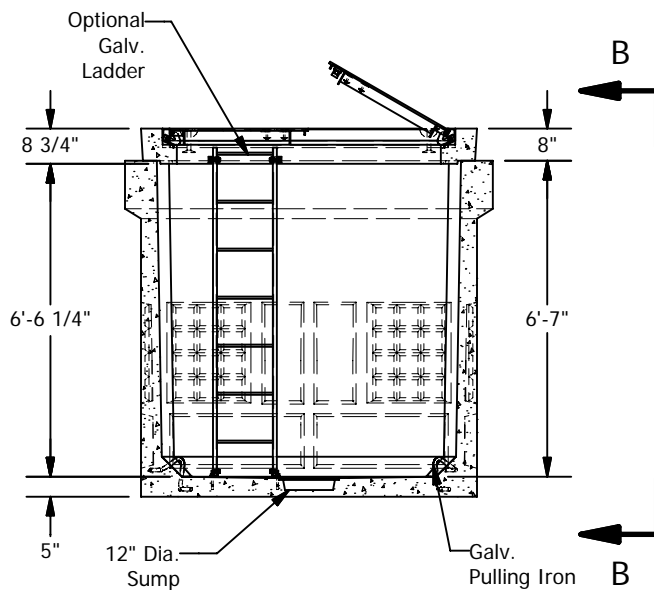

D-26

SPECIFICATIONS

1. Concrete: $f_c=5,000$ psi @28 days
2. Rebar: ASTM A-615 Grade 60
3. Design: ASTM C-857 "Minimum Structural Design Loading for Underground Precast Concrete Utility Structures"
4. Loads: AASHTO HS-20
5. Backfill with granular free draining material (sand or pea gravel) free of stones or cobbles greater than 4" in dia.
6. Holes cored to plan specifications.
7. Install lid prior to backfill.
8. Items shown are subject to change without notice.