

7 x 12 Grease Interceptor

3,500 Gallon
Capacity

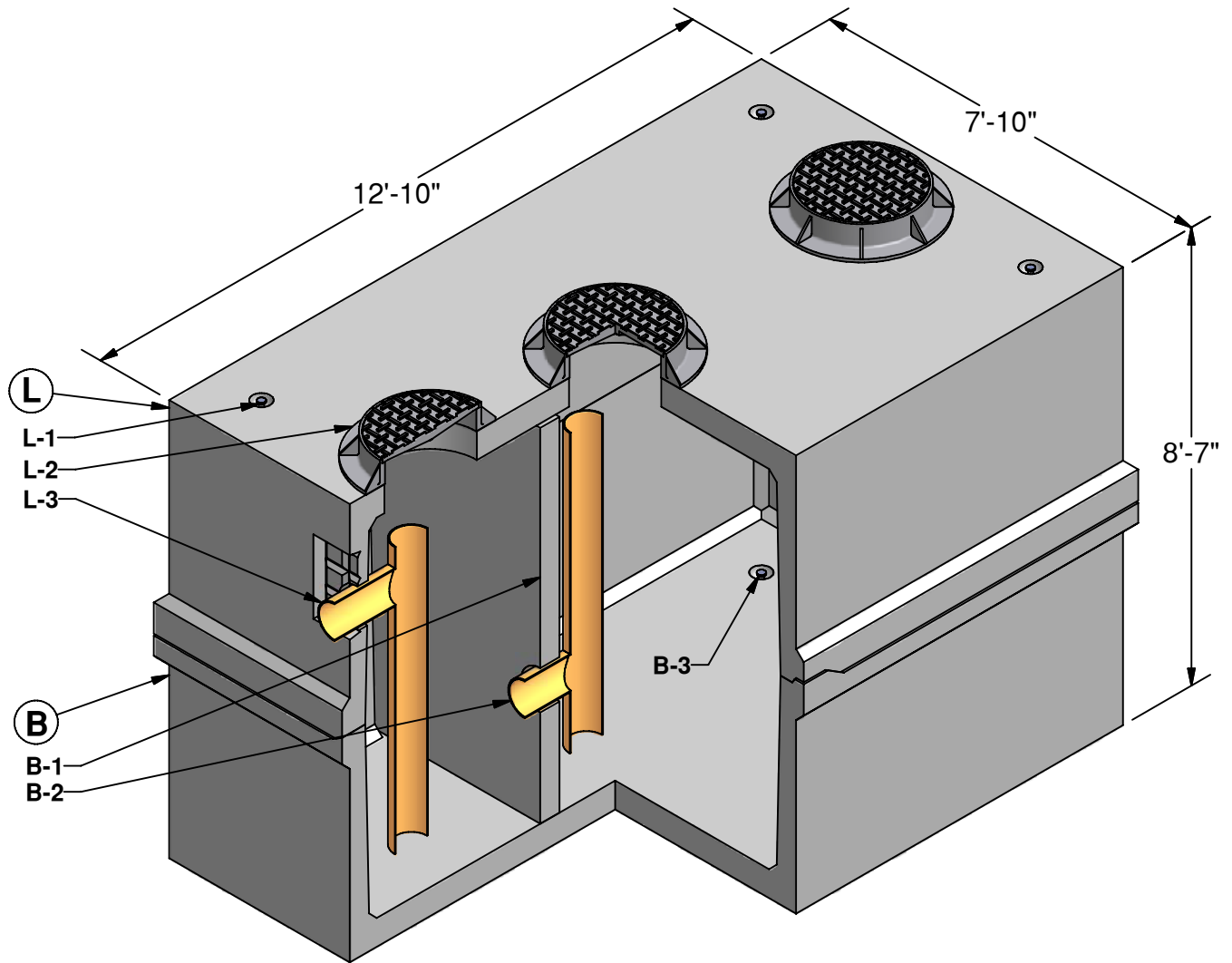

L LID (17,335 lbs)

- L-1. LIFTING INSERT
- L-2. 24" DIA. RING & COVER (OPTIONAL)
- L-3. OUTLET PIPE AND TEE (BY OTHERS)

B BASE (21,360 lbs)

- B-1. BAFFLE
- B-2. INSPECTION TEE (BY OTHERS)
- B-3. LIFTING INSERT



GRANITETM

**PRECASTING &
CONCRETE INC.**

4116 BAKERVIEW SPUR • BELLINGHAM, WA. 98226 • (360) 671-2251 • 1-800-808-2251 • FAX: (360) 671-0780

7 x 12 Grease Interceptor

3,500 Gallon Capacity

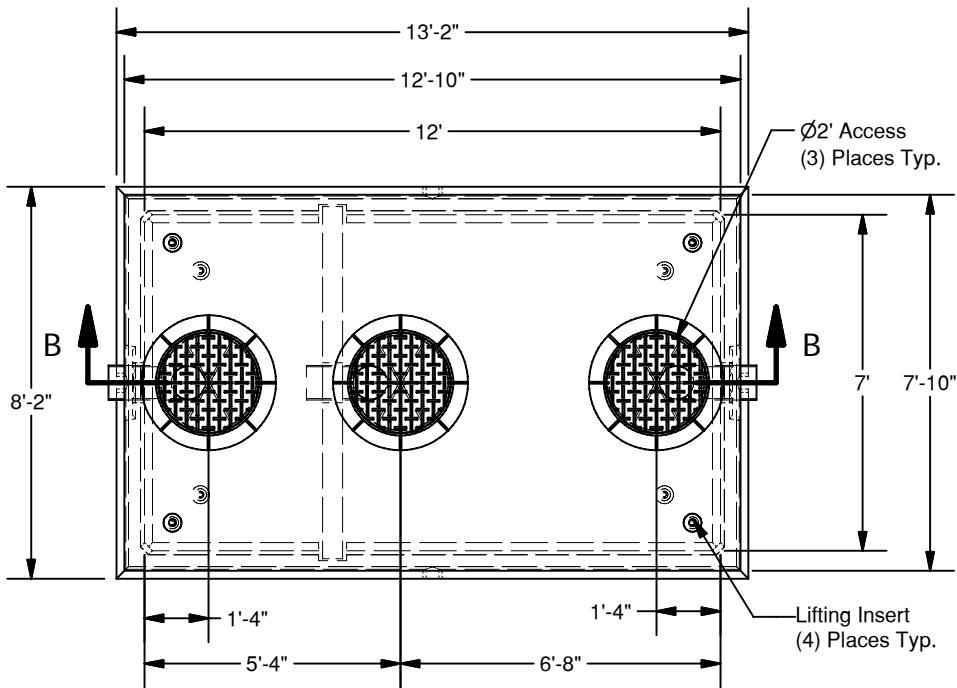

PLAN

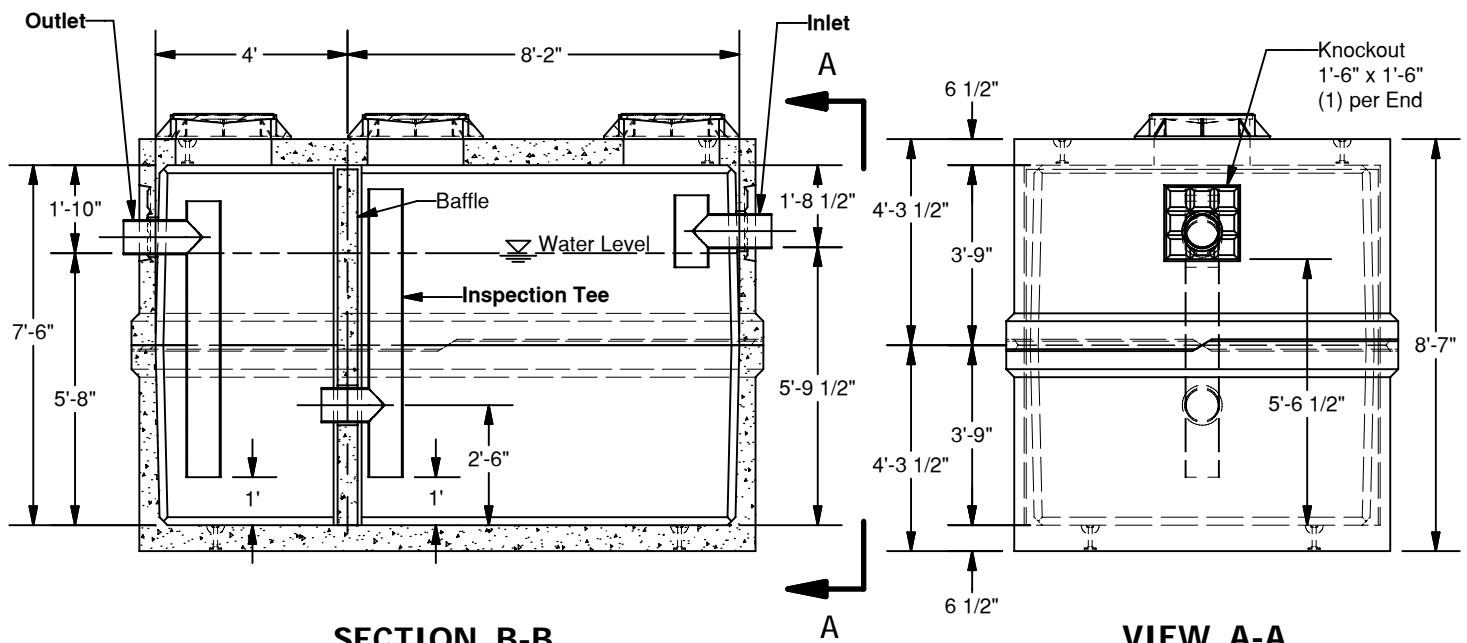

SECTION B-B

VIEW A-A

SPECIFICATIONS

1. Concrete: Fc=5,000 psi @ 28 days
2. Rebar: ASTM A-615 Grade 60
3. Design: ASTM C-857 "Minimum Structural Design Loading for Underground Precast Concrete Utility Structures"
4. Loads: AASHTO HS-20
5. Backfill with granular free draining material (sand or pea gravel) free of stones or cobbles greater than 4" dia.
6. All pipe to be supplied and installed by contractor.
7. Contractor to field install baffle.
8. Fill with clean water prior to start up.
9. Items shown are subject to change without notice.