

8 x 14 Electrical Vault

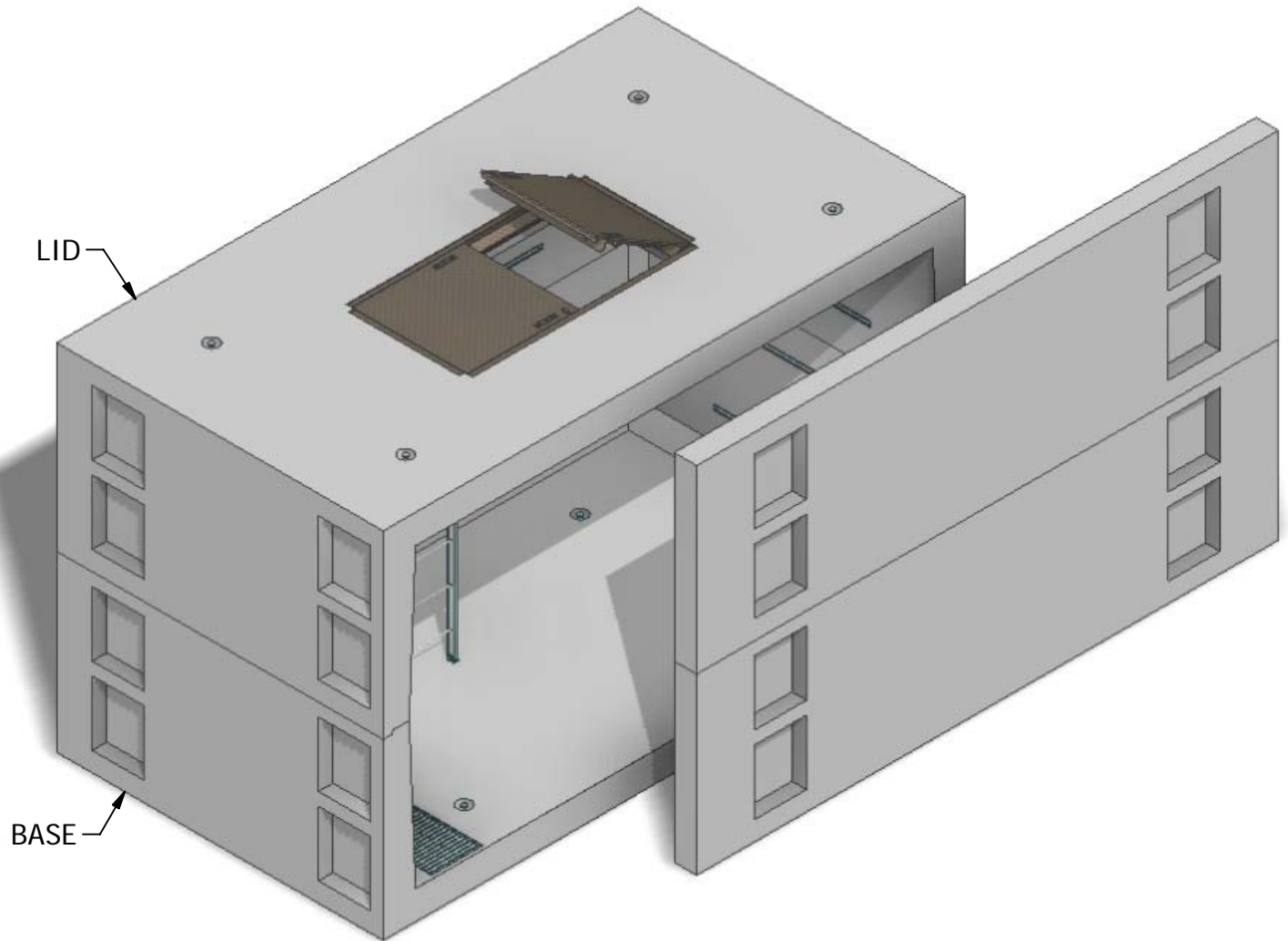

INTERIOR DIMENSIONS:
8'W x 14'L x 8'H

WEIGHTS:
LID (26,120 lbs)
BASE (27,140 lbs)

NOTE: Side panel has been shifted to show internal view and is not removable.

© 2011 Granite Precasting & Concrete, Inc.



GRANITETM

**PRECASTING &
CONCRETE INC.**

4116 BAKERVIEW SPUR • BELLINGHAM, WA. 98226 • (360) 671-2251 • 1-800-808-2251 • FAX: (360) 671-0780

8 x 14 Electrical Vault

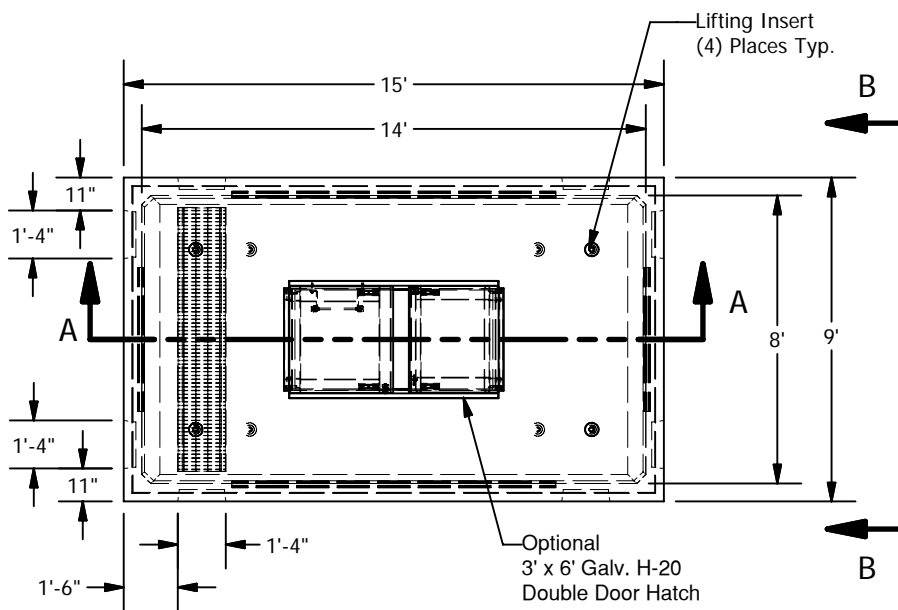

PLAN

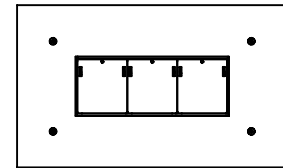

8' x 14' Lid
w/ 33" x 100"
Galv. Hatch

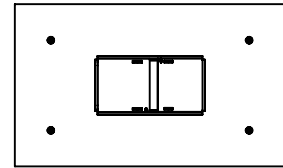

8' x 14' Lid
w/ 3' x 3' Hatch

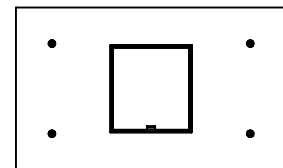

8' x 14' Lid
w/ 4' x 4' Hatch

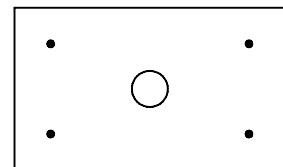

8' x 14' Lid
w/ 24", 30", 36",
42", or 48" Dia.
Opening

LID OPTIONS

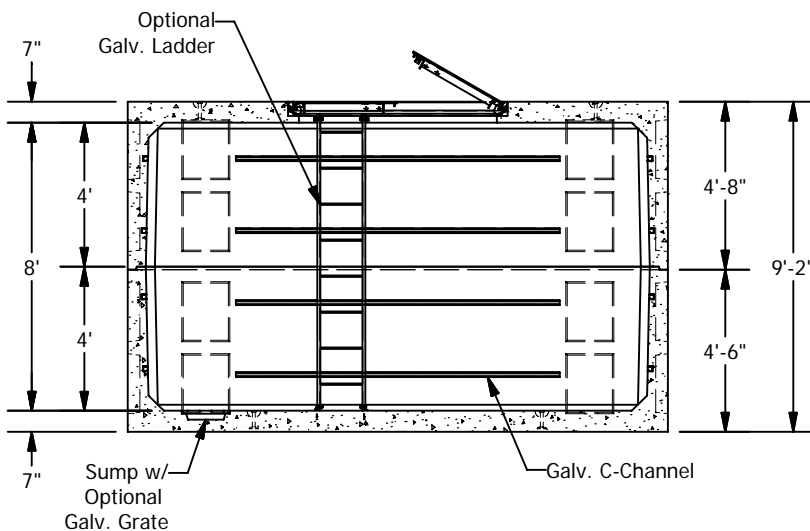

SECTION A-A

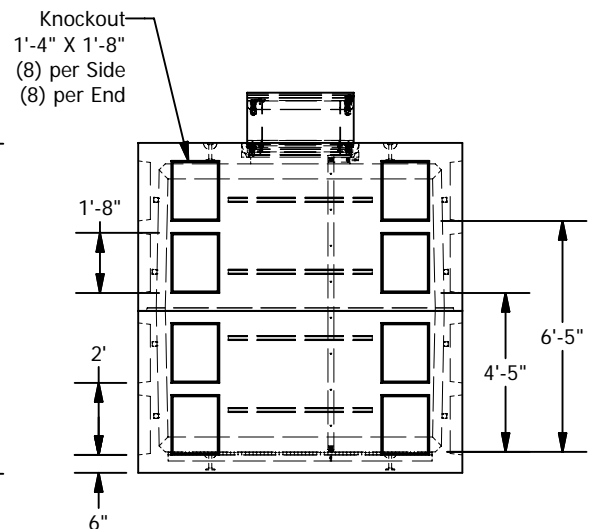

VIEW B-B

© 2011 Granite Precasting & Concrete, Inc.

SPECIFICATIONS

1. Concrete: $F_c=5,000$ psi @28 days
2. Rebar: ASTM A-615 Grade 60
3. Design: ASTM C-857 "Minimum Structural Design Loading for Underground Precast Concrete Utility Structures"
4. Loads: AASHTO HS-20
5. Backfill with granular free draining material (sand or pea gravel) free of stones or cobbles greater than 4" in dia.
6. Holes cored to plan specifications.
7. Install lid prior to backfill.
8. Items shown are subject to change without notice.