

8 x 18 Electrical Vault

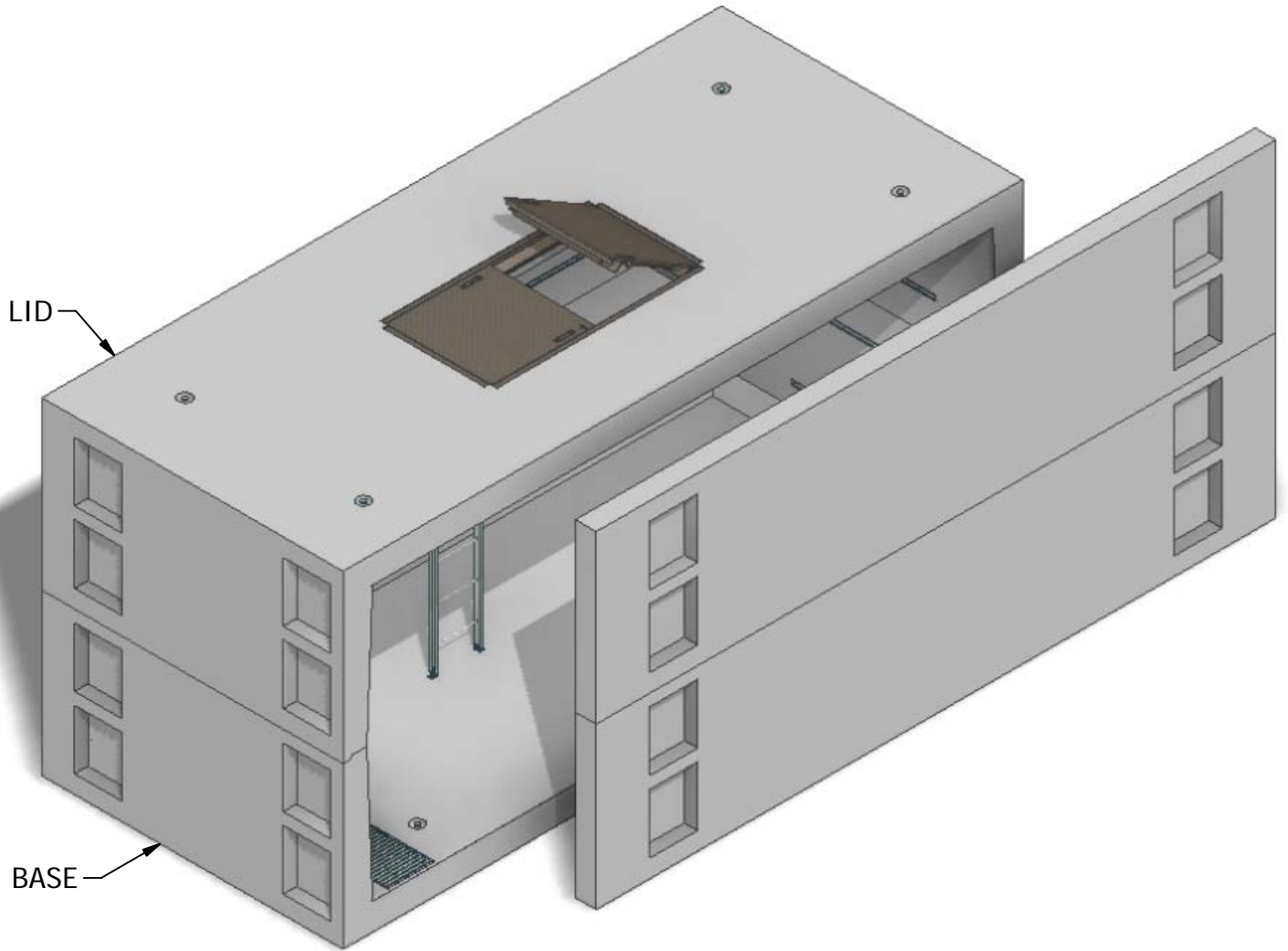

INTERIOR DIMENSIONS:
8'W x 18'L x 8'H

WEIGHTS:
LID (31,980 lbs)
BASE (33,000 lbs)

NOTE: Side panel has been shifted to show internal view and is not removable.

© 2011 Granite Precasting & Concrete, Inc.



GRANITETM

**PRECASTING &
CONCRETE INC.**

4116 BAKERVIEW SPUR • BELLINGHAM, WA. 98226 • (360) 671-2251 • 1-800-808-2251 • FAX: (360) 671-0780

8 x 18 Electrical Vault

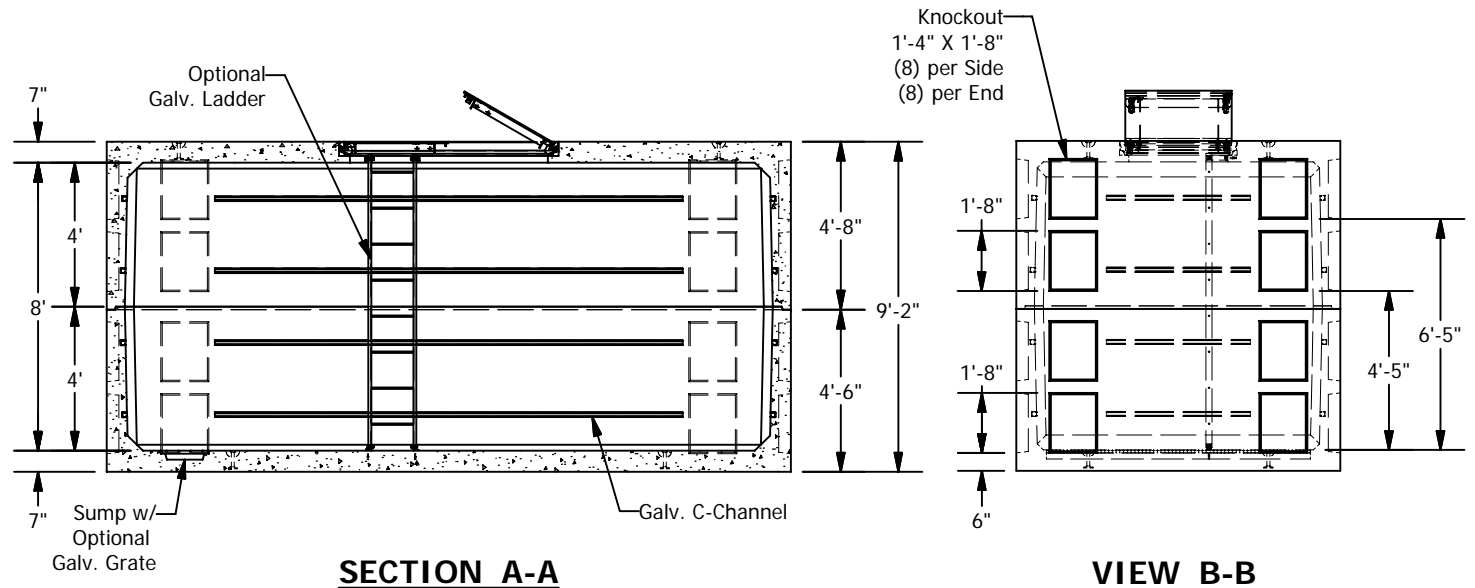
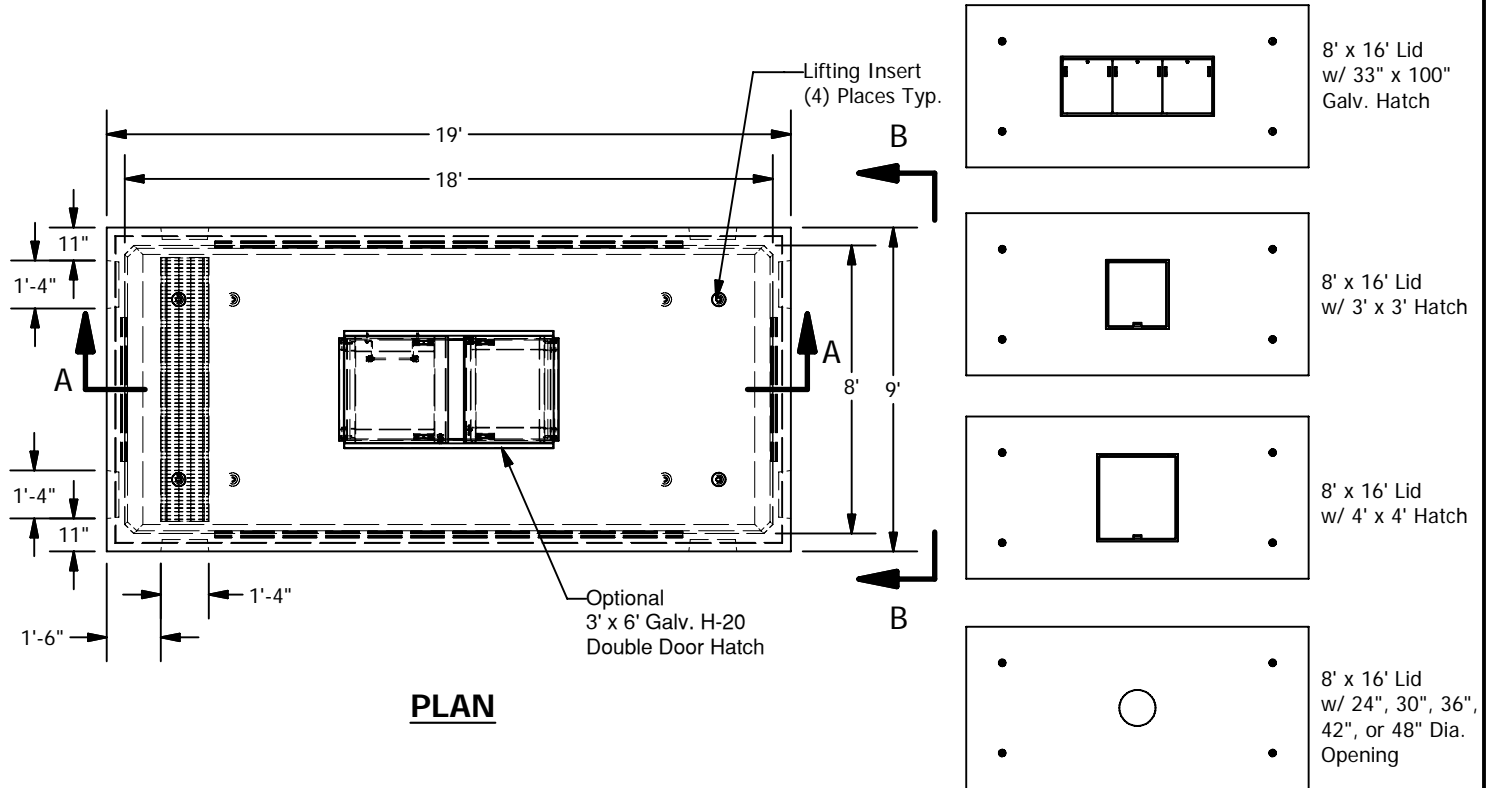

© 2011 Granite Precasting & Concrete, Inc.

SPECIFICATIONS

- Concrete: $F_c=5,000$ psi @28 days
- Rebar: ASTM A-615 Grade 60
- Design: ASTM C-857 "Minimum Structural Design Loading for Underground Precast Concrete Utility Structures"
- Loads: AASHTO HS-20
- Backfill with granular free draining material (sand or pea gravel) free of stones or cobbles greater than 4" in dia.
- Holes cored to plan specifications.
- Install lid prior to backfill.
- Items shown are subject to change without notice.