

8 x 10 Coalescing Separator 1

Projected Plate Area: 2,073 Sq/ft
Max. Process Flow Rate: 1,960 GPM

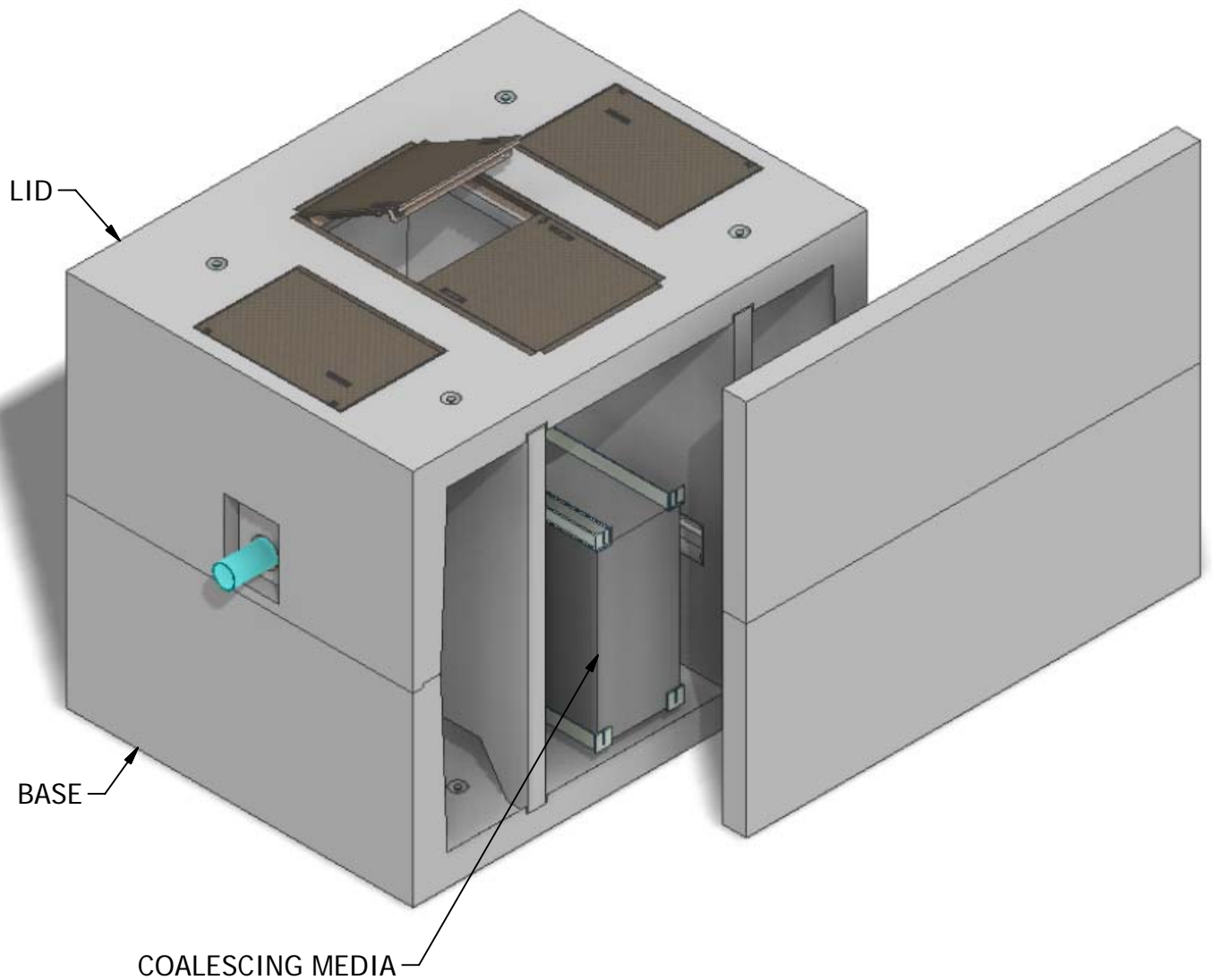

INTERIOR DIMENSIONS:
8'W x 10'L x 8'H

WEIGHTS:
LID (21,340 lbs)
BASE (29,340 lbs)

NOTE: Side panel has been shifted to show internal view and is not removable.

© 2011 Granite Precasting & Concrete, Inc.



GRANITETM

**PRECASTING &
CONCRETE INC.**

4116 BAKERVIEW SPUR • BELLINGHAM, WA. 98226 • (360) 671-2251 • 1-800-808-2251 • FAX: (360) 671-0780

8 x 10 Coalescing Separator 1

Projected Plate Area: 2,073 Sq/ft
Max. Process Flow Rate: 1,960 GPM

BASIC DESIGN INFORMATION

Design Flow = 520 GPM
Influent Oil Concentration = 100 ppm
Operating Temperature = 50 deg. F
Sized to Remove 60 micron and larger
Oil Specific Gravity = 0.88
Oil Rise Rate = 0.033 ft/min
Effluent Quality PPM
Designed per WA State Dept. of Ecology
"Volume V Runoff Treatment BMPs",
Chapter 11, August 2001

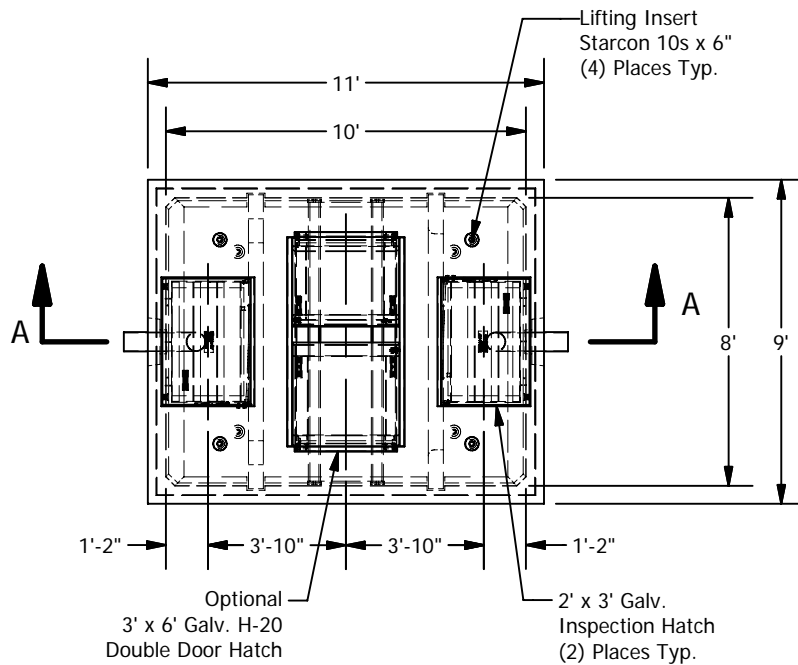

PLAN

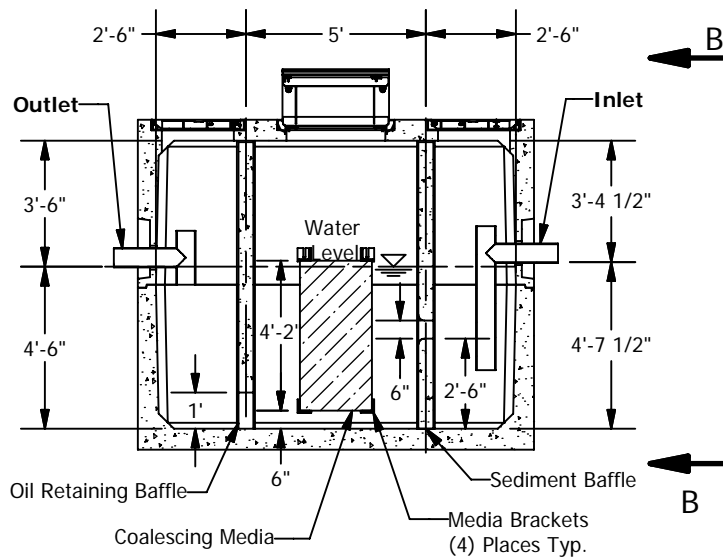

SECTION A-A

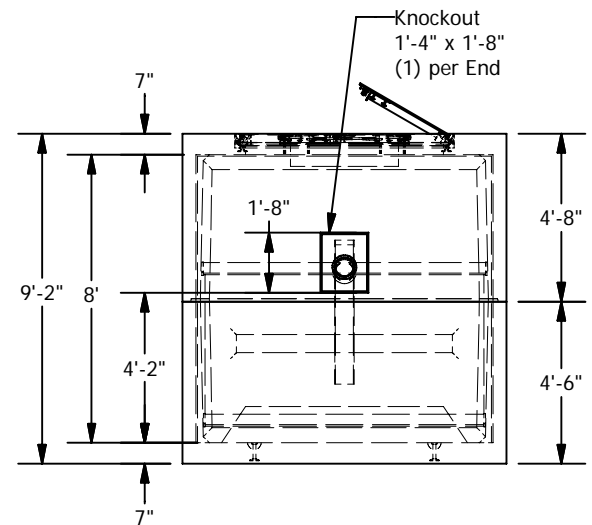

VIEW B-B

© 2011 Granite Precasting & Concrete, Inc.

SPECIFICATIONS

1. Concrete: Fc=5,000 psi @ 28 days
2. Rebar: ASTM A-615 Grade 60
3. Design: ASTM C-857 "Minimum Structural Design Loading for Underground Precast Concrete Utility Structures"
4. Loads: AASHTO HS-20
5. Backfill with granular free draining material (sand or pea gravel) free of stones or cobbles greater than 4" dia.
6. All pipe to be supplied and installed by contractor.
7. Contractor to field install baffle.
8. Fill with clean water prior to start up.
9. Items shown are subject to change without notice.