

8 x 16 Oil Water Separator

4,100 Gallon
Capacity

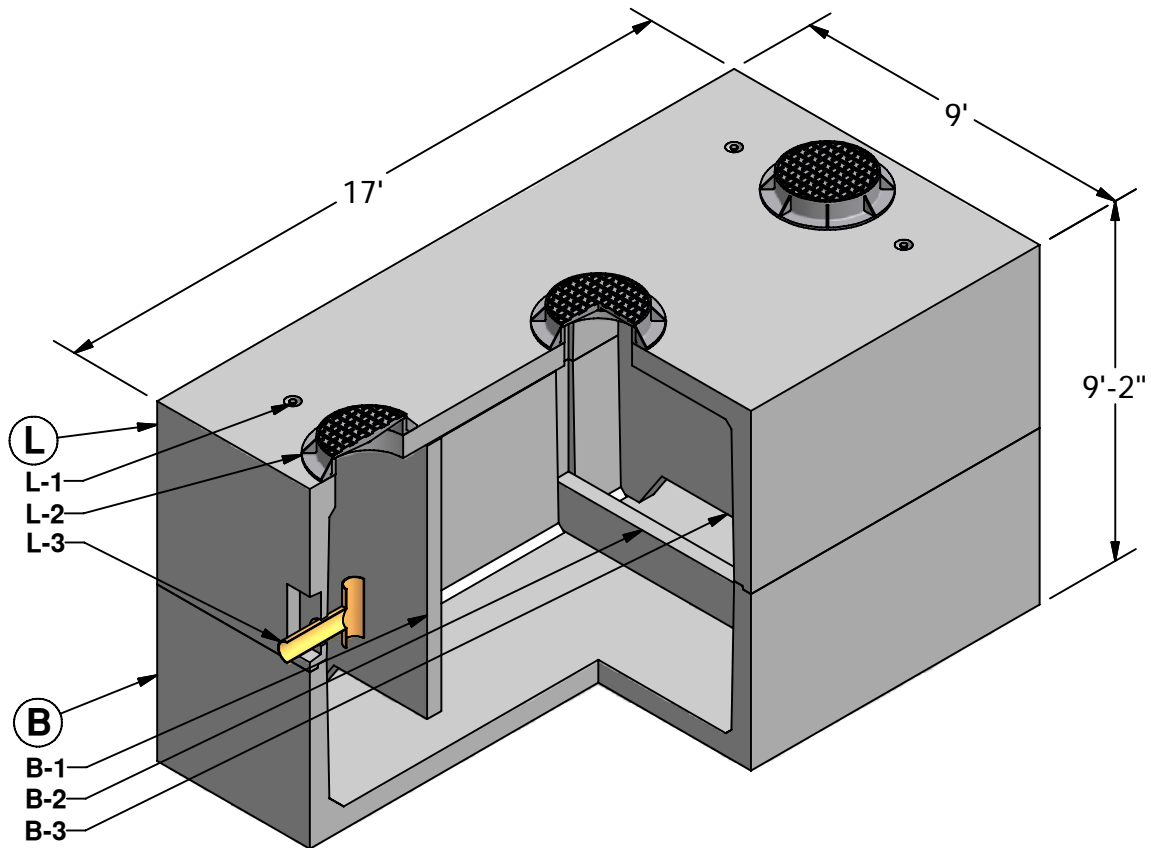

Ⓛ LID (29,220 lbs)

- L-1. LIFTING INSERT
- L-2. 24" DIA. RING & COVER (OPTIONAL)
- L-3. OUTLET PIPE AND TEE (BY OTHERS)

ⓑ BASE (38,040 lbs)

- B-1. OIL RETAINING BAFFLE
- B-2. SLUDGE WEIR
- B-3. FLOW DIFFUSER BAFFLE



GRANITETM

**PRECASTING &
CONCRETE INC.**

4116 BAKERVIEW SPUR • BELLINGHAM, WA. 98226 • (360) 671-2251 • 1-800-808-2251 • FAX: (360) 671-0780

8 x 16 Oil Water Separator

4,100 Gallon Capacity

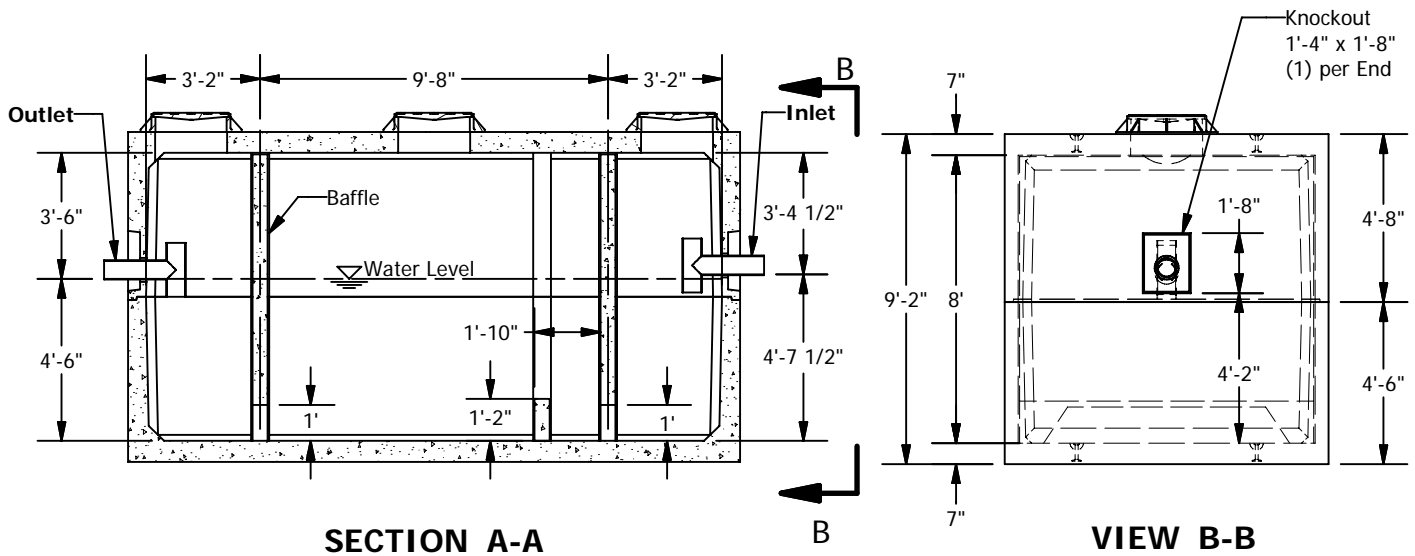
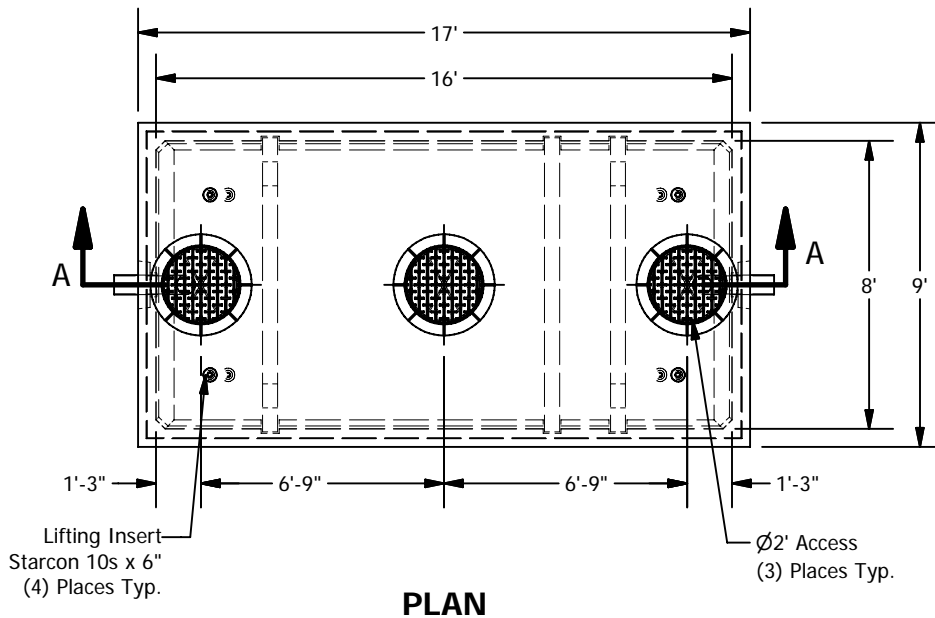

SPECIFICATIONS

- Concrete: $f_c=5,000$ psi @ 28 days
- Rebar: ASTM A-615 Grade 60
- Design: ASTM C-857 "Minimum Structural Design Loading for Underground Precast Concrete Utility Structures"
- Loads: AASHTO HS-20
- Backfill with granular free draining material (sand or pea gravel) free of stones or cobbles greater than 4" dia.
- All pipe to be supplied and installed by contractor.
- Contractor to field install baffle.
- Fill with clean water prior to start up.
- Items shown are subject to change without notice.