

Port of Seattle Parking Barrier

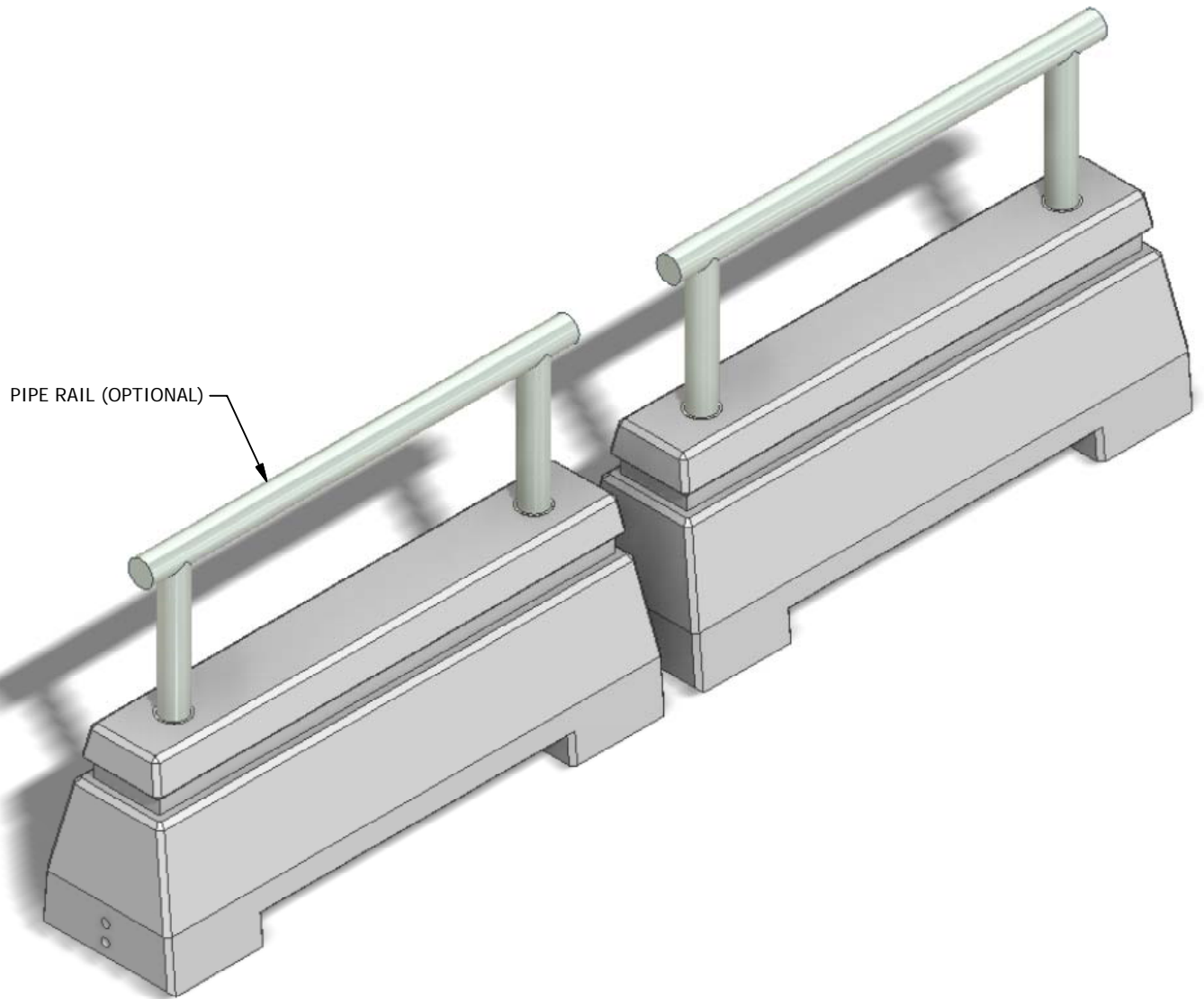

© 2011 Granite Precasting & Concrete, Inc.



GRANITETM

**PRECASTING &
CONCRETE INC.**

4116 BAKERVIEW SPUR • BELLINGHAM, WA. 98226 • (360) 671-2251 • 1-800-808-2251 • FAX: (360) 671-0780

Port of Seattle Parking Barrier



PLAN VIEW

DESIGN NOTES:

- 1) Concrete: $F_c = 6,000$ psi @ 28 Days
- 2) Reinforcement: ASTM A-615 Grade 60
- 3) 1 1/2" Bar Cover Typ.
- 4) Weight = 1,350 lbs. (~270 lb/ft)
- 5) Concrete Barrier designed to withstand 1,500 lbs. horizontal impact (18" Above Grade).
(Note, Potential exists for units to slide or overturn with 1,500 lb. load. Granite Precasting can not be responsible for overall stability of system.)

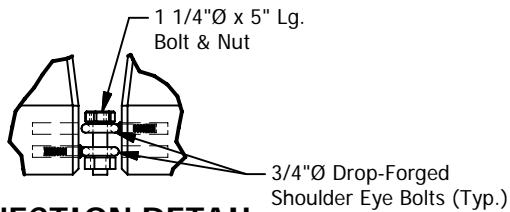

CONNECTION DETAIL

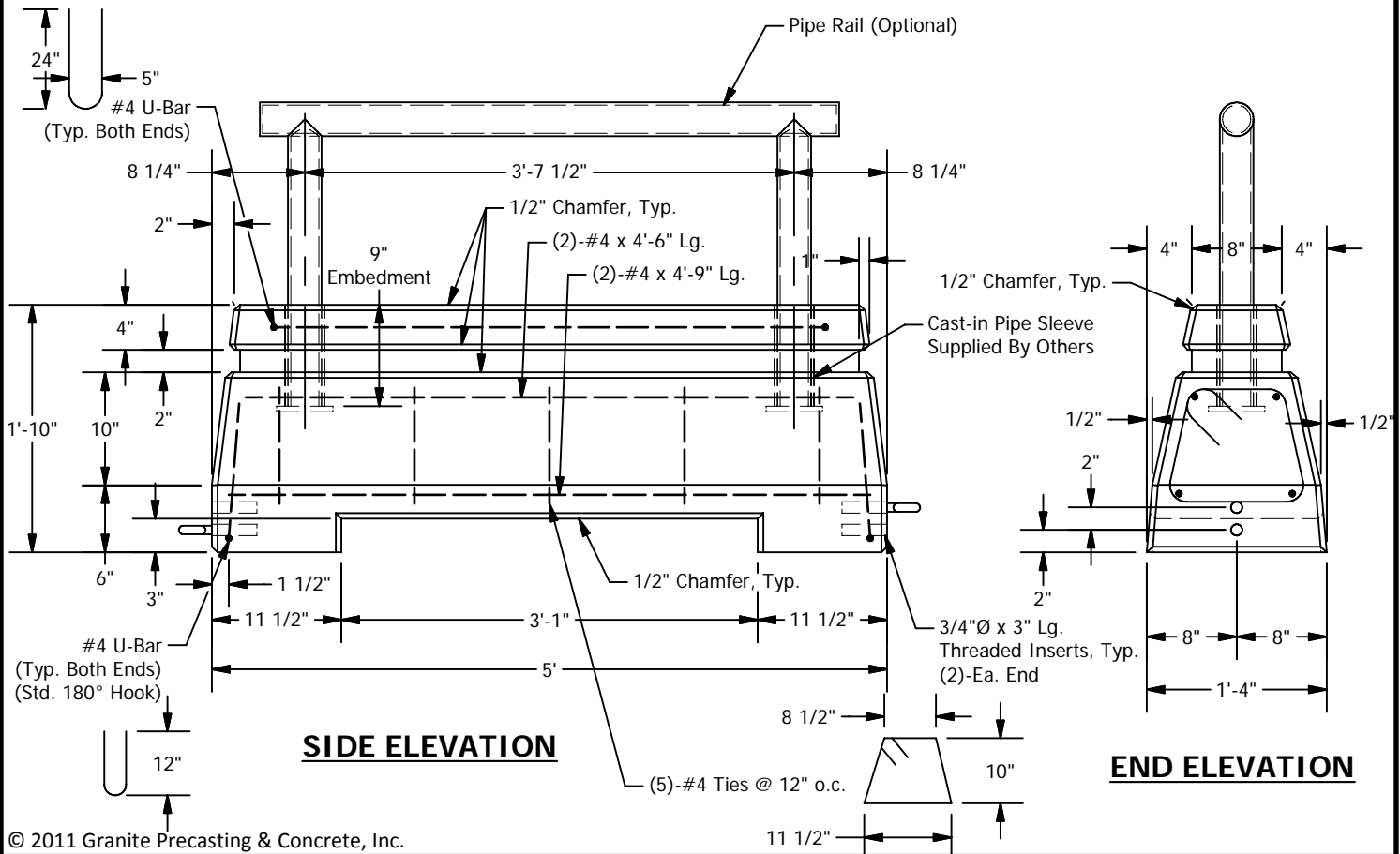
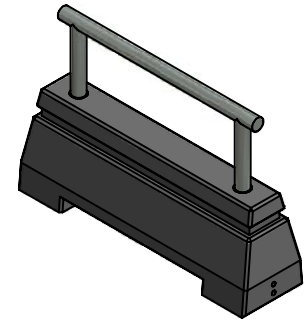

© 2011 Granite Precasting & Concrete, Inc.



GRANITE™

PRECASTING & CONCRETE INC.

4116 BAKERVIEW SPUR • BELLINGHAM, WA. 98226 • (360) 671-2251 • 1-800-808-2251 • FAX: (360) 671-0780