

Tangent Block

Meets or Exceeds WSDOT Std. Plan F-10.62-01

CONCRETE:

Fc= 4,000 psi @ 28 Days

REINFORCING STEEL:

Rebar: ASTM A-615 Grade 60

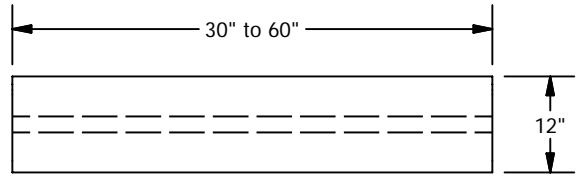
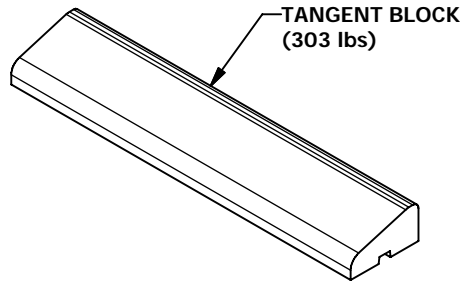

PLAN

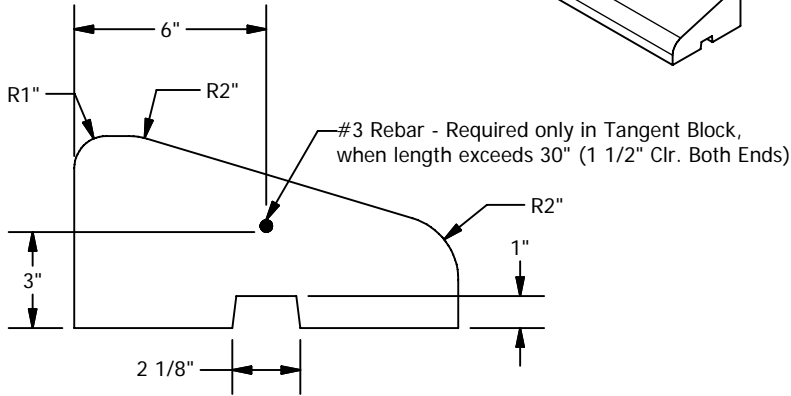

END VIEW

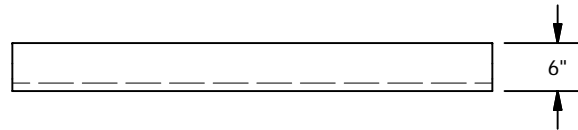

ELEVATION

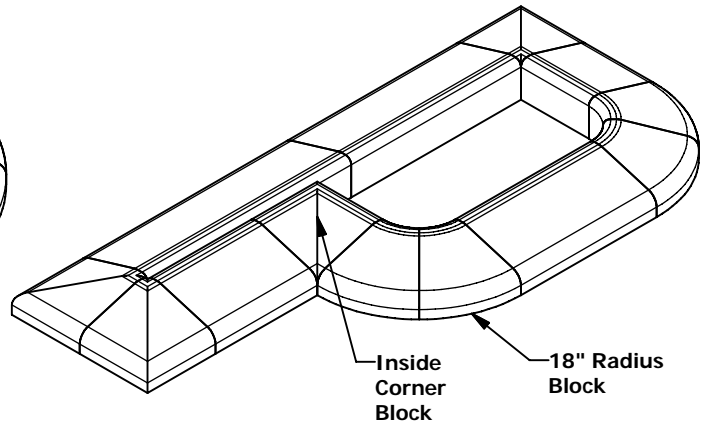
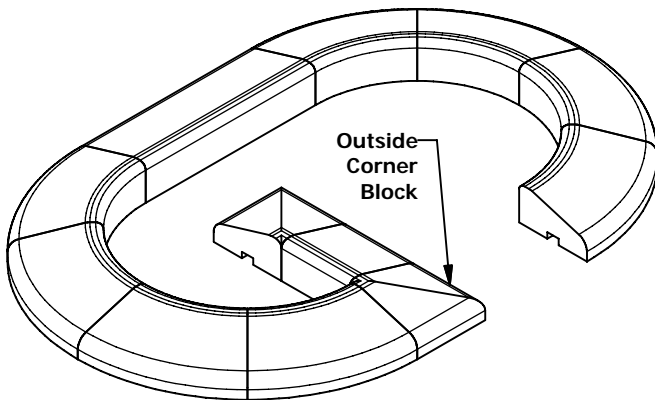

3-D VIEW

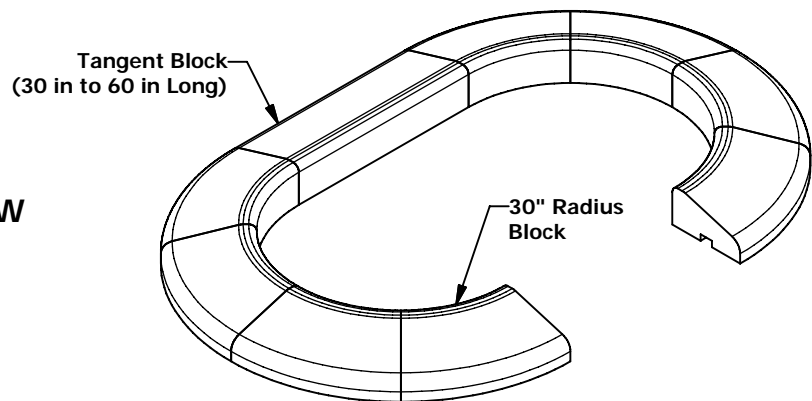

© 2011 Granite Precasting & Concrete, Inc.



GRANITE™

PRECASTING & CONCRETE INC.

4116 BAKERVIEW SPUR • BELLINGHAM, WA. 98226 • (360) 671-2251 • 1-800-808-2251 • FAX: (360) 671-0780