

# 72" Type 2 Catch Basin

Meets or Exceeds WSDOT Std Plan B-10.20-01  
 Catch Basins Constructed in Accordance With ASTM C-478  
 Rubber Gasket Conforms to ASTM C-443  
 Polypropylene MH Steps Conform to ASTM C-478

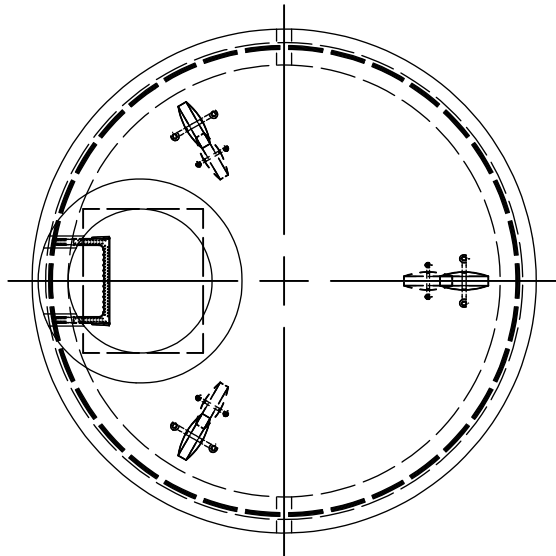

## TOP SLAB

24" Diameter Round or 20" x 24" Rectangular Hole

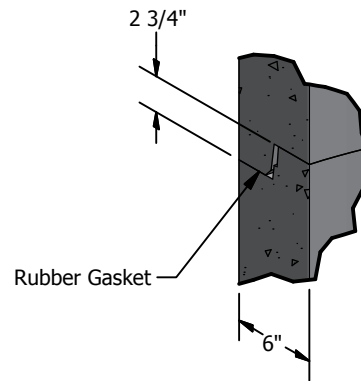

## JOINT DETAIL A SCALE 1/12

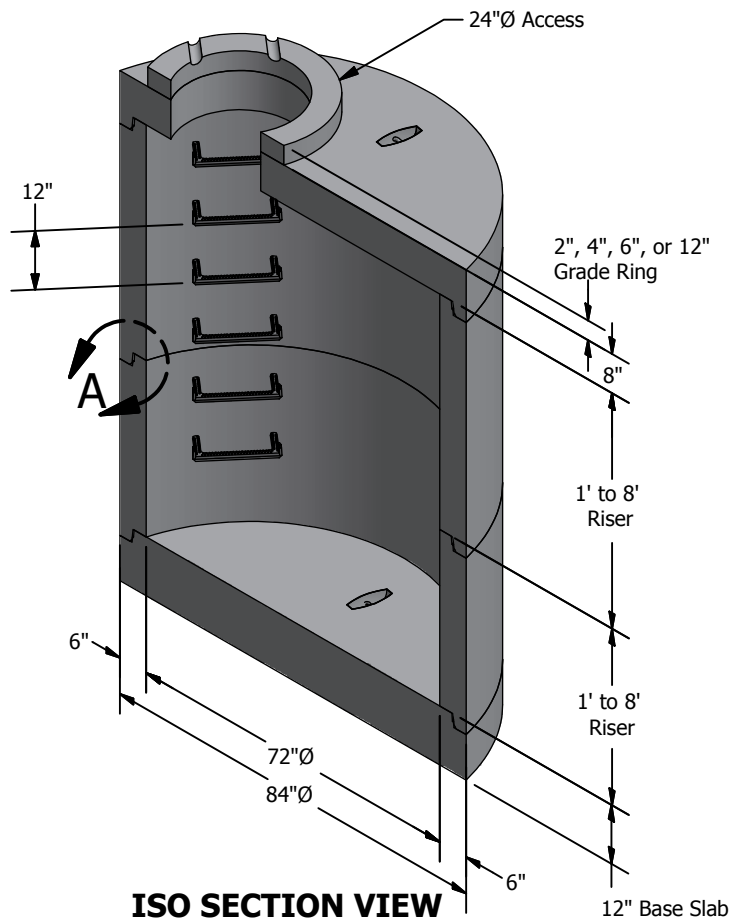

## ISO SECTION VIEW

### WEIGHTS:

TOP SLAB:	8" - 3,620 lbs
RISER:	1' - 1,500 lbs
	2' - 3,000 lbs
	3' - 4,500 lbs
	4' - 6,000 lbs
	5' - 7,500 lbs
	6' - 9,000 lbs
	7' - 10,500 lbs
	8' - 12,000 lbs
BASE SLAB:	12" - 5,300 lbs

### CONCRETE:

Fc = 4,000 psi @ 28 Days

### REINFORCING STEEL:

Welded Wire Fabric: ASTM A497  
 Rebar: ASTM A615 Grade 60  
 Top Slab: 0.62 Sq in./ft. e.w. min.  
 Riser: 0.18 Sq in./ft. e.w. min.  
 Base Slab: 0.35 Sq in./ft. e.w. min.

### PIPE PENETRATIONS:

Maximum Hole Size: 60"  
 Minimum Distance Hole to Hole: 12"  
 Holes Cored to Plan Specifications  
 Kor-N-Seal Connections Available  
 Standard Knockouts Available

### SITE PENETRATIONS:

Contractor to Establish Level Grade  
 Prior to Setting Base Piece at a  
 Tolerance of 1/4" to 3/8"

© 2013 Granite Precasting & Concrete, Inc.



4116 BAKERVIEW SPUR, BELLINGHAM, WA 98226 - (360) 671-2251 - 1-800-808-2251 - FAX: (360) 671-0780