

6 x 12 Coalescing Separator 2

Projected Plate Area: 2,721 Sq/ft
Max. Process Flow Rate: 1,293 GPM

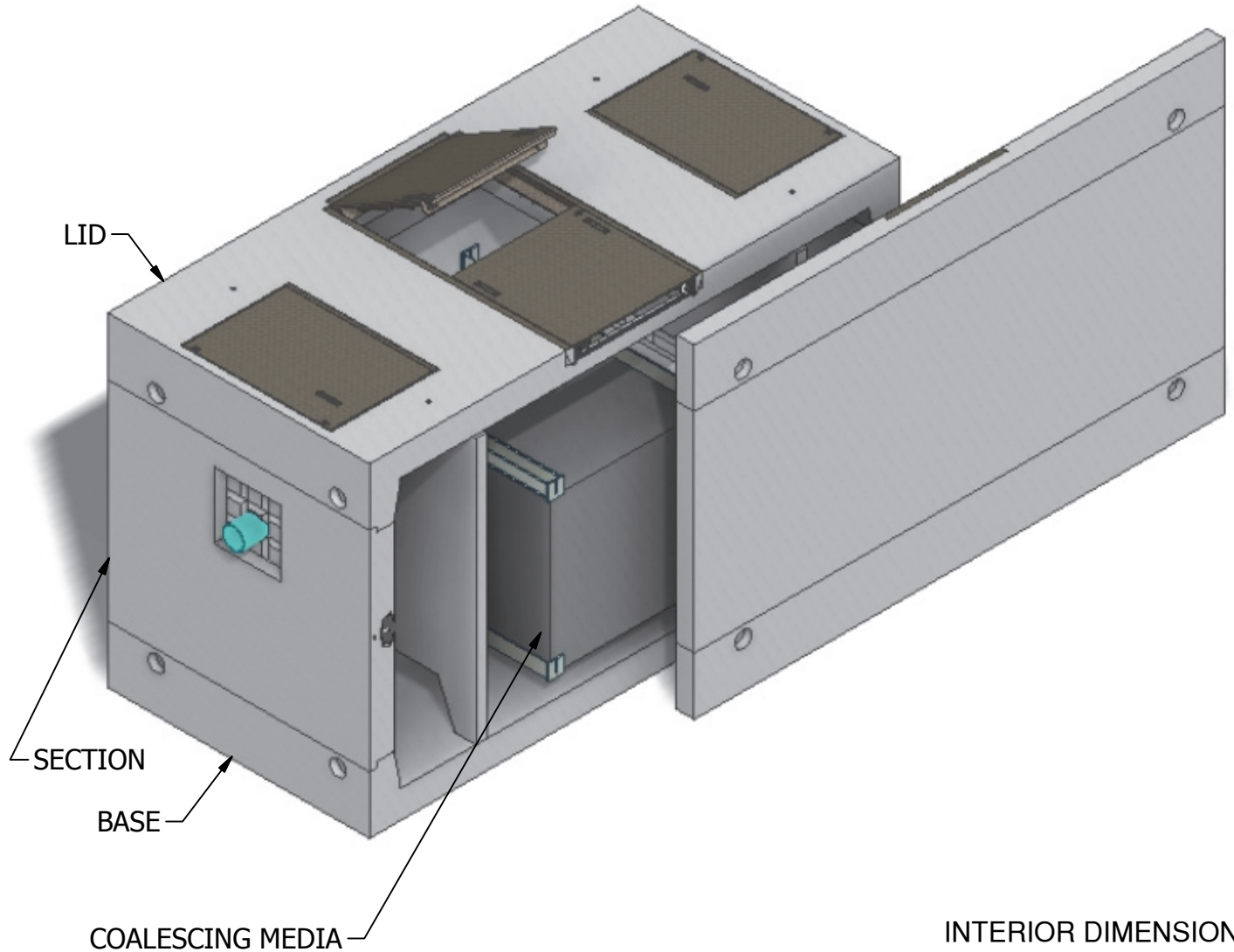

INTERIOR DIMENSIONS:
6'W x 12'L x 6'-5"H

WEIGHTS:
LID (7,600 lbs)
SECTION (12,600 lbs)
BASE (9,680 lbs)

NOTE: Side panel has been shifted to show internal view and is not removable.

© 2013 Granite Precasting & Concrete, Inc.



4116 BAKERVIEW SPUR, BELLINGHAM, WA 98226 - (360) 671-2251 - 1-800-808-2251 - FAX: (360) 671-0780

6 x 12 Coalescing Separator 2

Projected Plate Area: 2,721 Sq/ft
Max. Process Flow Rate: 1,293 GPM

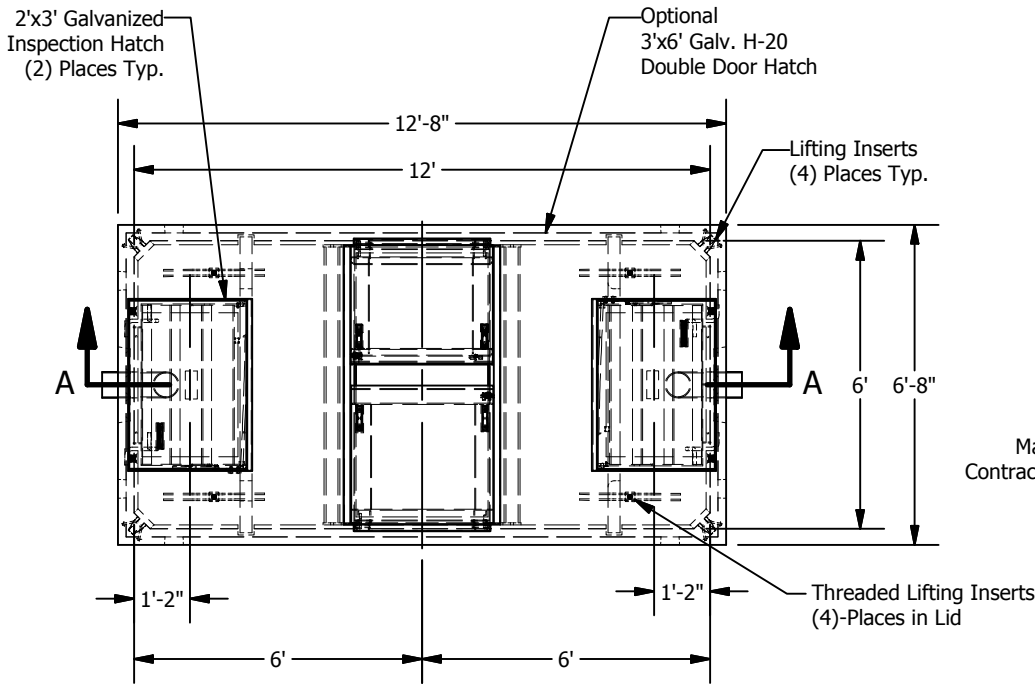

PLAN

BASIC DESIGN INFORMATION
 Design Flow = 683 GPM
 Influent Oil Concentration = 100 ppm
 Operating Temperature = 50 deg. F
 Sized to Remove 60 micron and larger
 Oil Specific Gravity = 0.88
 Oil Rise Rate = 0.033 ft/min
 Effluent Quality = 10 PPM
 Designed per WA State Dept. of Ecology
 "Volume V Runoff Treatment BMPs",
 Chapter 11, August 2001

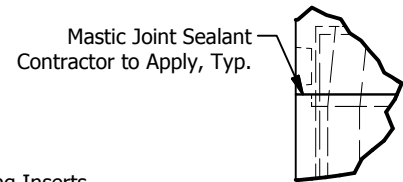

JOINT DETAIL D
SCALE 1 / 24

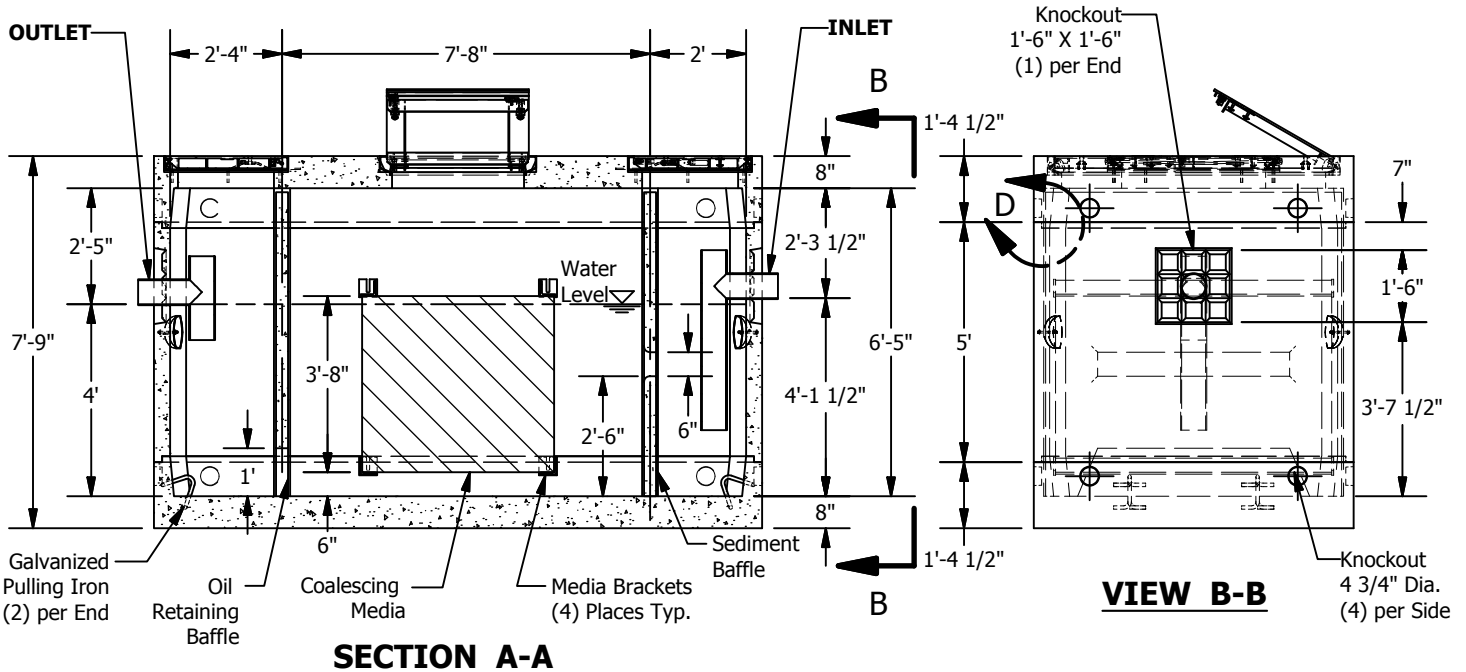

SECTION A-A

VIEW B-B

© 2013 Granite Precasting & Concrete, Inc.

SPECIFICATIONS

- Concrete: Fc=5,000 psi @ 28 days
- Rebar: ASTM A-615 Grade 60
- Design: ASTM C-857 "Minimum Structural Design Loading for Underground Precast Concrete Utility Structures"
- Loads: AASHTO HS-20
- Backfill with granular free draining material (sand or pea gravel) free of stones or cobbles greater than 4" dia.
- All pipe to be supplied and installed by contractor.
- Contractor to field install baffle.
- Fill with clean water prior to start up.
- Items shown are subject to change without notice.