

5 x 7.5 Grease Interceptor

500 Gallon
Capacity

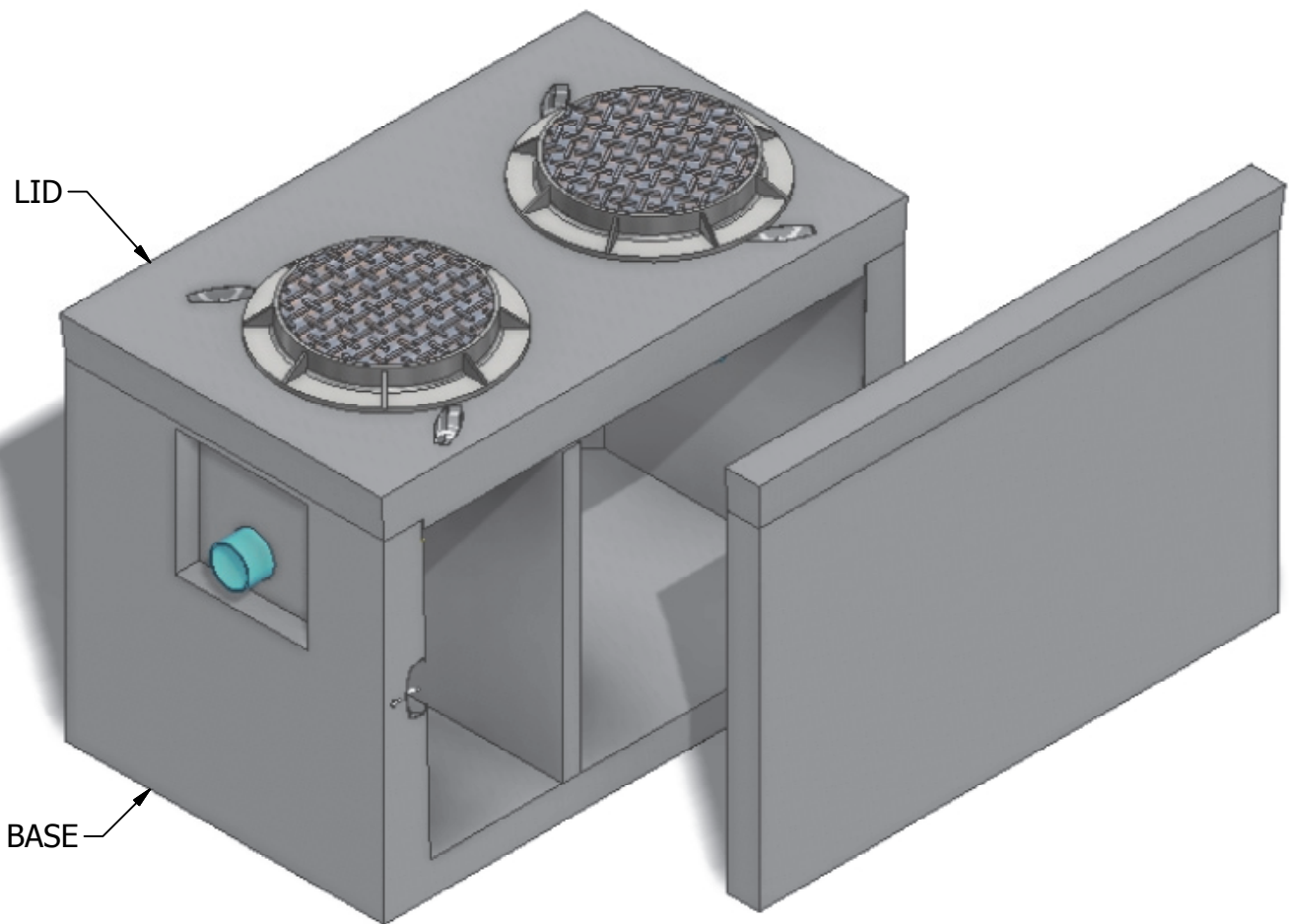

INTERIOR DIMENSIONS:
4'-0"W x 6'-4"L x 4'-0"H

WEIGHTS:
LID (2,700 lbs)
BASE (7,760 lbs)

NOTE: Side panel has been shifted to show internal view and is not removable.

© 2013 Granite Precasting & Concrete, Inc.



4116 BAKERVIEW SPUR, BELLINGHAM, WA 98226 - (360) 671-2251 - 1-800-808-2251 - FAX: (360) 671-0780

5 x 7.5 Grease Interceptor

500 Gallon Capacity

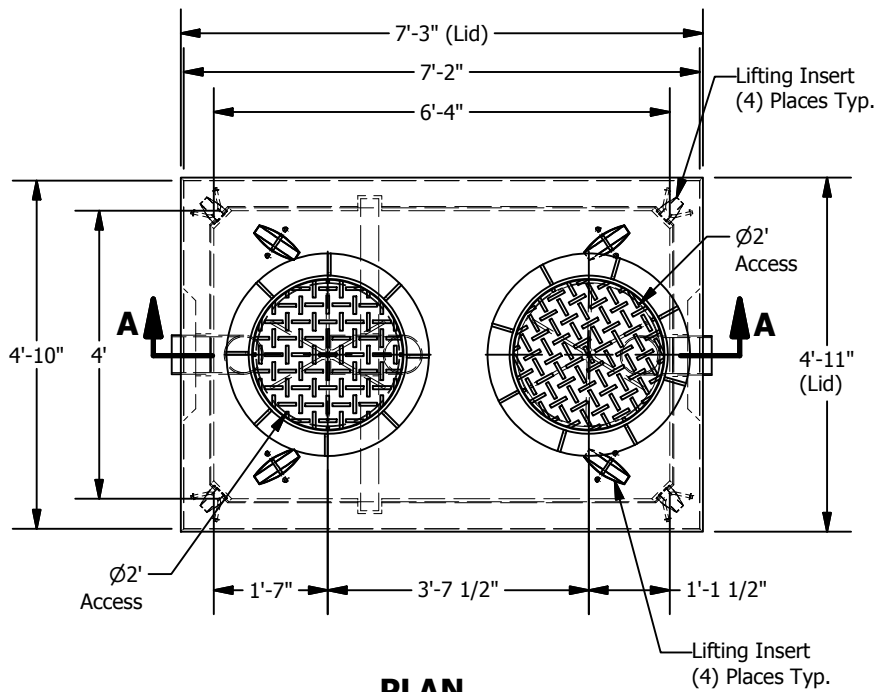

PLAN

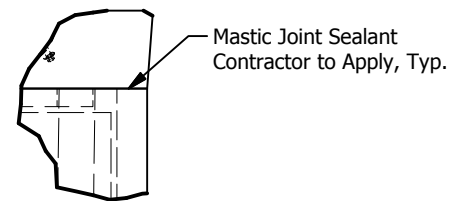

JOINT DETAIL D
SCALE 1 / 16

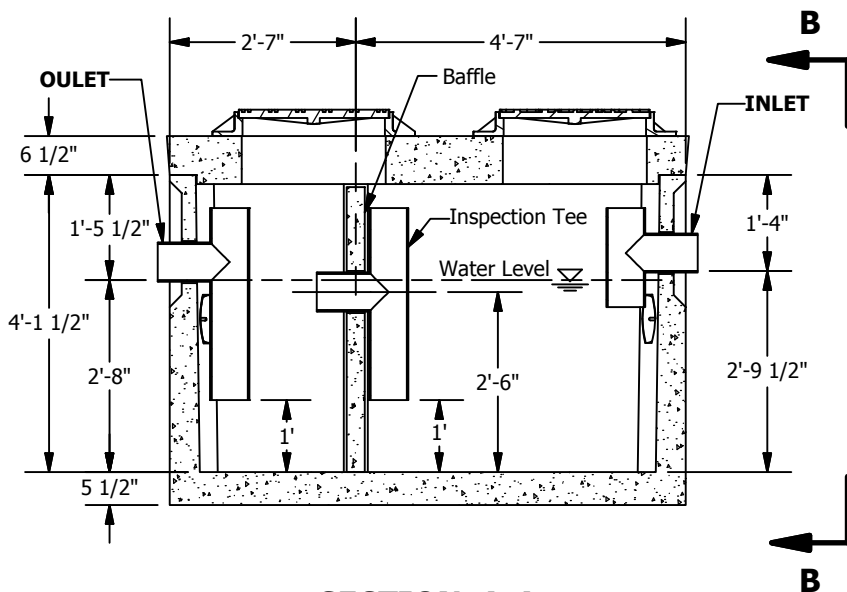

SECTION A-A

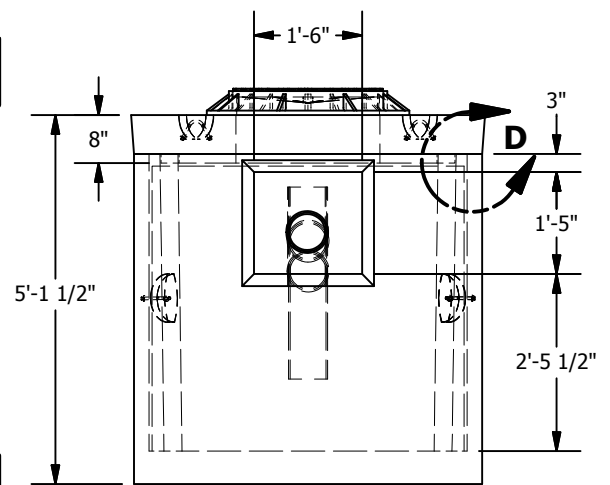

VIEW B-B

© 2013 Granite Precasting & Concrete, Inc.

SPECIFICATIONS

1. Concrete: Fc=5,000 psi @ 28 days
2. Rebar: ASTM A-615 Grade 60
3. Design: ASTM C-857 "Minimum Structural Design Loading for Underground Precast Concrete Utility Structures"
4. Loads: AASHTO HS-20
5. Backfill with granular free draining material (sand or pea gravel) free of stones or cobbles greater than 4" dia.
6. All pipe to be supplied and installed by contractor.
7. Contractor to field install baffle.
8. Fill with clean water prior to start up.
9. Items shown are subject to change without notice.