

# 5 x 7.5 Oil Water Separator

500 Gallon  
Capacity

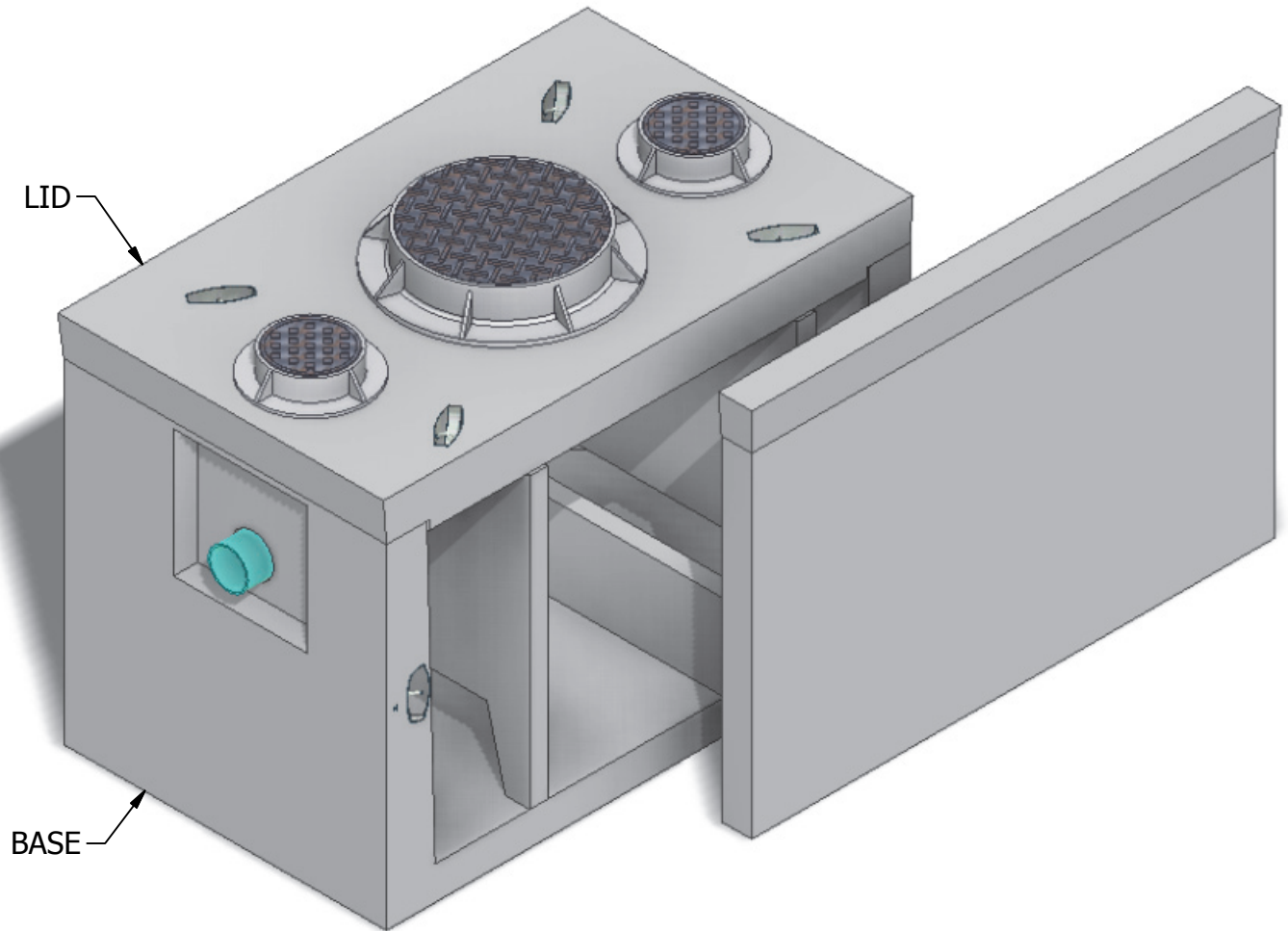

INTERIOR DIMENSIONS:  
4'-0"W x 6'-4"L x 4'-0"H

WEIGHTS:  
LID (2,750 lbs)  
BASE (8,460 lbs)

NOTE: Side panel has been shifted to show internal view and is not removable.

© 2013 Granite Precasting & Concrete, Inc.



**GRANITE**™  
**PRECAST**

4116 BAKERVIEW SPUR, BELLINGHAM, WA 98226 - (360) 671-2251 - 1-800-808-2251 - FAX: (360) 671-0780

# 5 x 7.5 Oil Water Separator

500 Gallon Capacity

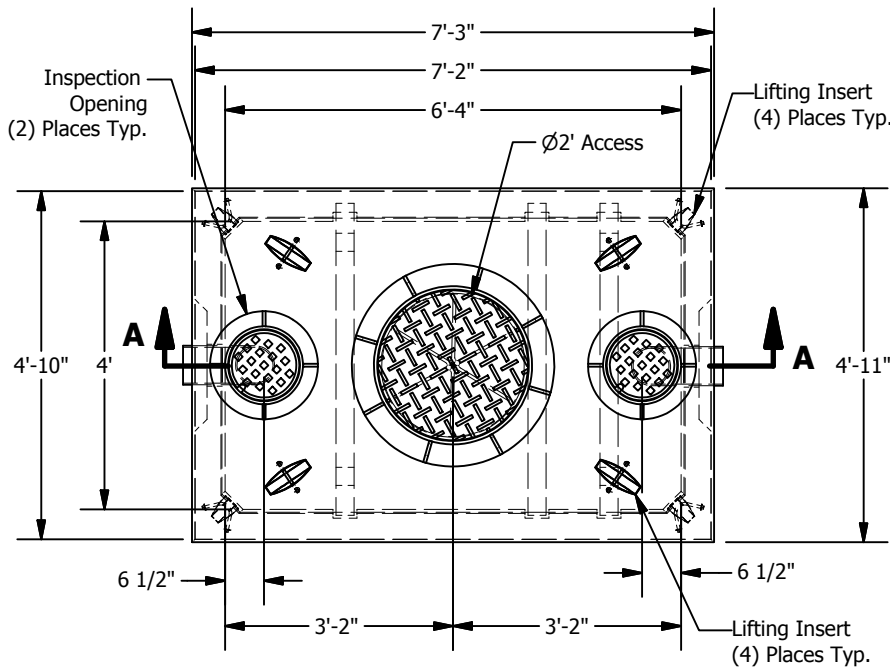

**PLAN**

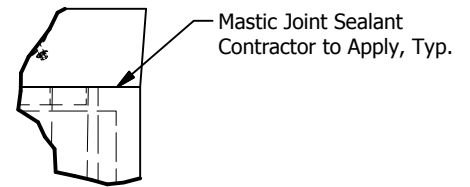

**JOINT DETAIL D**  
**SCALE 1 / 16**

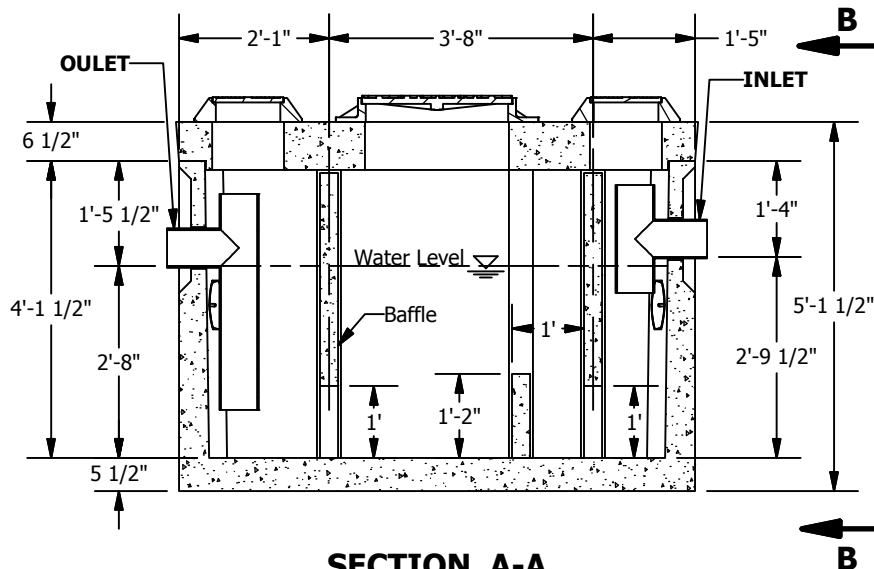

**SECTION A-A**

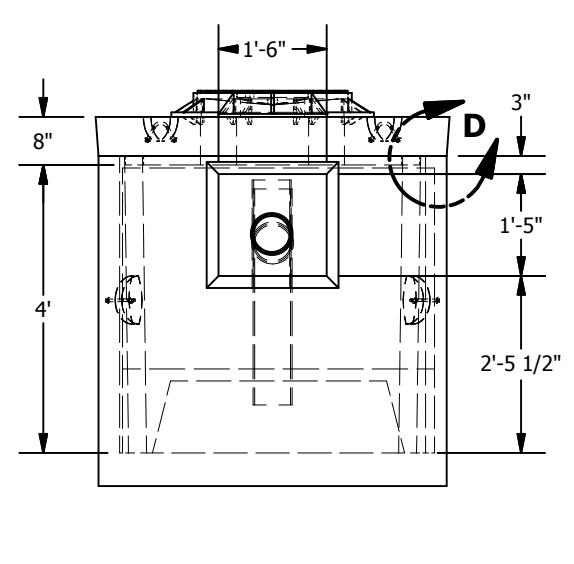

**VIEW B-B**

© 2013 Granite Precasting & Concrete, Inc.

**SPECIFICATIONS**

- Concrete: Fc=5,000 psi @ 28 days
- Rebar: ASTM A-615 Grade 60
- Design: ASTM C-857 "Minimum Structural Design Loading for Underground Precast Concrete Utility Structures"
- Loads: AASHTO HS-20
- Backfill with granular free draining material (sand or pea gravel) free of stones or cobbles greater than 4" dia.
- All pipe to be supplied and installed by contractor.
- Contractor to field install baffle.
- Fill with clean water prior to start up.
- Items shown are subject to change without notice.